

X-LASER

LASER WITHOUT LIMITS



Skywriter HPX M-5, M-10, M-20, M-30, M-40

Product Manual and User Guide

For Professional Use Only - FDA Variance Required in the United States

X-Laser strongly recommends keeping this manual with your laser projector at all times as a field reference.



Review the safety and legal notices in this manual carefully before use.

If you have any questions about any of the content of this manual or the safe operation of your new laser projector, please do not hesitate to contact your dealer or X-Laser directly.



301-543-1981

866-702-7768

Sales – Dial 1

Support – Dial 2

General Information – Dial 0

support@x-laser.com

www.x-laser.com

info@x-laser.com

9115H Whiskey Bottom Road, Laurel, MD 20723 USA

Table of Contents

Introduction	6
A note on Mercury equipped projectors	6
Product Labeling	7
Safety Notices	8
Legal Notice	9
Unpacking Your Laser Projector	9
Projector Layout and Functions.....	10
Mercury Interface layout and functions	11
Power Variations.....	12
General Guidelines for Safe Laser Use.....	12
General Guidelines for Proper Usage	14
Installation	15
Safe Beam and Projection Height	15
Physical beam blocks	16
Operation	17
Before Powering up Your Projector	17
Duty Cycle	17
Laser Startup	17
The etherStop system	18
etherStop terminator.....	18
etherStop Pendant.....	19
The Mercury Menu system.....	23
System Status Display	23
System Menu	24
DMX Menu	25
Network Menu.....	25
Art-Net Menu.....	25
X/Y Menu	26
Colors Menu.....	27
Display Menu	27
Manual Operation Menu	28
Mercury Menu	28

Content Menu.....	28
Restoring settings	28
System Update Menu	29
Remote Management and Configuration.....	30
Previsualization.....	30
Controlling your laser projector	30
Master and builders.....	30
DMX Control	33
sACN Control.....	33
Art-Net Control	34
Auto Source Selection.....	34
Personalities.....	35
Control Groups.....	36
Correlation with moving lights	37
DMX Parameters.....	38
Gobo Guide	52
Prism Modes	56
Basic builder color presets.....	57
Basic builder motion presets	58
ILDA Control	59
ILDA Settings.....	60
Troubleshooting.....	61
Repair and Return Information.....	65
Product Registration	65
Return Material Authorization (RMA) and Shipping	65
Shipping within Continental USA.....	65
Shipping outside Continental USA.....	65
Out of Warranty Repairs.....	65
General Notification	65
Manufacturer’s Limited Warranty.....	66
Limitation of Liability	66
Return Policy.....	66
Sample Laser Operator Show Checklist	66

Sample Laser Signage.....	68
Document History.....	69
Questions? Feedback?	70

Introduction

Thank you for purchasing an X-Laser product! You now own one of the most powerful and best crafted aerial laser display systems ever created for the entertainment industry.

Before leaving our factory, every projector is carefully checked in a comprehensive quality assurance process to ensure proper and safe operation. In many cases, the quality assurance process is repeated to ensure that the data from the first quality check remains consistent. With this level of attention to detail, you can be sure that your new X-Laser has left our factory in absolutely perfect working order. Please check your laser immediately upon receipt to ensure that it was not damaged in shipping, which can happen with sensitive optical components.

Your new X-Laser projector is capable of producing absolutely stunning aerial laser effects over audiences in nearly any performance application with the convenience and flexibility of DMX control. With the power of X-Laser fixtures also comes a responsibility for safety so we strongly encourage you to read and follow all of the notices throughout this manual.

Please note that this User Guide is NOT exhaustive. For clients in the United States, Federal law requires that you use your X-Laser equipment only in compliance with the terms of your FDA variance. We also recommend that all of our clients, especially those who may be new to high powered laser, seek advice and further training from experienced laserists and laser safety officers. Light shows of any kind are always at their best when the designer understands the strengths and weakness of the medium and the equipment. This is especially true for laser, as the value of experience and training cannot be overstated when it comes to safely crafting the best possible laser display. If you have any questions about proper use of your laser system, laser safety, troubleshooting or anything else, visit us on the web 24/7 at www.x-laser.com so that we can best assist you!

A note on Mercury equipped projectors

Our laser control system, Mercury, was designed from the ground up specifically for use with modern production grade stage lighting control. There are sometimes substantial differences in the ways these control systems present the features of the Mercury system. To help you get started, we have created a series of video tutorials to show you all the basics of the system to help you get up and running on a wide range of different platforms. Often these videos are the fastest way to learn how to work with Mercury and we encourage you to check them out.

Please check these videos out on our website at

www.x-laser.com/mercury-tutorials

Product Labeling

Several labels are attached to your laser system. Each of these labels is required for compliance with US Federal Regulation and international standards. If at any point any label becomes illegible, contact X-Laser for a replacement.



Black- or White- Pattern Certification Label, usually located on the top of the laser. Contains important certification, serialization, and safety information.

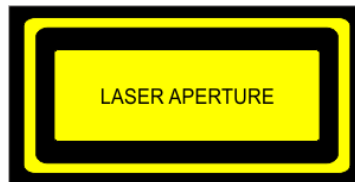

Laser Aperture Label, located adjacent to the laser aperture.

Caution--use of controls or adjustments or performance of procedures other than those specified herein may result in hazardous radiation exposure.

Safety Notices

Failure to follow the above precautions and other precautions contained in this user manual, particularly with regard to human exposure to laser radiation and electrical safety, may result in serious injury, loss of vision, electric shock, skin damage, and death. Please refer to the section on safe laser projector usage later in this manual for more detailed operation guidelines. Always be mindful that Class 3B and 4 lasers shoot potentially hazardous radiation at the speed of light. They should be handled and operated with care and caution.

1. This equipment should only be set up and operated by qualified personnel and under the supervision of a qualified Laser Safety Officer.
2. **Do not expose the human eye directly or indirectly to focused or scattered laser radiation as loss of vision, complete blindness, and/or other serious injuries may result. Lasers are capable of starting fires at great distances. Do not use around flammable materials.**
3. This fixture is NOT intended for audience scanning effects. Operators must ensure that the primary laser beam and any reflected beams remain in designated safe areas only. Please refer to the terms of your specific FDA variance for vertical and lateral separation requirements. In most cases, to prevent human access to the laser beam all beams are required to pass no closer than 3m (10ft.) above any surface upon which someone can stand.
4. Always ensure that the fixture is mounted securely to prevent accidental beam shifts.
5. Always ensure that the main power supply is properly grounded before use. Do not use an ungrounded power cable with this fixture.
6. Always provide both a primary and backup means of instantly terminating laser emissions.
7. Always test your means of termination before every performance.
8. DO NOT USE this fixture if you suspect that it contains a defect of any kind due to manufacturing, damage, general wear or if the fixture has a broken manufacturer's seal. Return the fixture to the factory for service and/or maintenance immediately.
9. **DO NOT EVER allow lasers to enter airspace or hit aircraft.**
10. This unit should never be left unattended while operational and should always be disconnected from both signal and power while being transported, rigged, de-rigged, cleaned, or when a qualified operator is not present. We also recommend removing the key from your etherStop pendant to prevent unwanted activation by untrained users.
11. Do not stand in front of the laser while active. All persons should wear protective eyewear while rigging, maintaining, or otherwise working with the laser.
12. There are NO user serviceable parts inside of the fixture. Opening the outer casing may result in radiation exposure. Any modifications to the fixture are prohibited, may be dangerous, and require recertification by the manufacturer to maintain compliance with US Federal regulations.
13. Service operations other than those described in this manual must be carried out only by a qualified technician in accordance with manufacturer's specified procedures.

Legal Notice

1. Before using this product, it is the responsibility of the user to be familiar with all Federal and State reporting and usage requirements for high powered laser demonstration equipment. Laws vary by state. Refer to the included user USB drive for more information.
2. In the United States, federal law requires that this product be operated by an FDA variance holder or an authorized and adequately trained employee under the supervision of an FDA variance holder. In all cases, this product should only be operated by qualified personnel and should be kept inaccessible to unauthorized persons before, during, and after use. Keep away from minors.
3. The labels and emission indicator on this product are required for compliance with US Federal law and international standards and must be kept on the unit, visible, and in legible condition at all times. Do not remove any labels and do not cover the emission indicator or laser aperture label under any circumstances. If any labels become damaged, contact X-Laser for replacement.
4. This product must be certified by the manufacturer to comply with US Federal requirements for laser demonstration equipment after manufacturing, modification, or alteration. The use of laser demonstration equipment that has not been recertified by the manufacturer after any alteration or modification is a violation of US Federal Regulations.
5. To maintain compliance with US Federal requirements, this product must only be operated and serviced in accordance with the manufacturer's specified procedures, including the procedures described in this manual.

Failure to comply with federal, state, or other applicable laws, codes, and/or standards of practice when using this product may cause serious and permanent injury and may result in civil or criminal penalties including fines and jailtime. Such failures to comply may be grounds for cancellation of liability or other insurance policies and increase the liability exposure of the user.

Unpacking Your Laser Projector

Your new X-Laser Skywriter HPX laser projector box should contain the following items:

1. X-Laser Skywriter HPX M-5 laser projector
2. A grounded powercon True1 cable
3. Laser projector key
4. etherStop terminator
5. "Black wrap" beam blocking foil
6. A USB key containing this manual, letters, forms, and a wealth of other information about this product and laser safety in general

Projector Layout and Functions



1. PowerCON True One inlet
2. PowerCON True One outlet
3. Power Switch
4. Fuse holder
5. Key Switch
6. 5 pin DMX Through
7. 5 pin DMX Input
8. DMX status indicator
9. etherStop ports
10. etherStop indicators
11. ILDA input/through
12. Mercury interface

Mercury Interface layout and functions

1. LCD Screen
2. USB Port for firmware and content updates
3. Signal status indicators
4. Laser emission indicator
5. Keypad

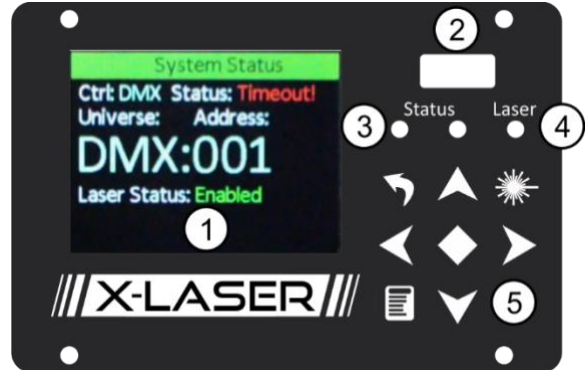

Directional buttons



Back button



Enter button



Menu button



Laser button

Power Variations

Laser systems often exhibit minor variations in power level between units, especially between systems of different ages. X-Laser systems are built to match from unit to unit within a small tolerance that is usually not noticeable. Variations within that tolerance are not considered a defect, even if they may be noticeable in certain applications. Contact X-Laser before purchasing if you require more closely matched systems.

General Guidelines for Safe Laser Use

This product is a powerful laser device intended to be operated by professionals. The major concern with professional laser systems is to avoid human contact with the laser beam and to create a safe area where patrons and staff can enjoy your light show. Please observe the following guidelines when using your X-Laser product:

Safe Zoning

Laser effects should only be projected in areas away from people and flammable materials and free of surfaces that may reflect laser beams towards people. People should be prevented from entering those projection zones at all times. If at any point a person enters the projection zone or for any reason any laser leaves the projection zone the laser display should be immediately terminated.

Prevent Mishaps

As a laser light show operator you have a responsibility to reasonably foresee circumstances where conditions could present a safety risk to people. This means that you must make sure all laser units are properly aimed via your show programming and securely mounted to prevent shifting during operation, physically blocked to prevent radiation spill or reflection into safe areas, and securely mounted. To ensure that these conditions are met properly, trained employees should be the only ones rigging or operating X-Laser products.

Means of Termination

Always provide primary and backup means of terminating the laser output in case of emergency. For example, DMX control as well as a remote etherStop pendant for the Skywriter HPX series. Always test both primary and backup means of termination before every performance.

Warning: DMX distribution or network control equipment that implements a “last look hold” feature is not a reliable means of termination. Such equipment may continue to provide a control signal that causes laser emission after a termination command from or even the total failure of the main control system.

Service and Maintenance

Because there are no user serviceable parts inside of this product, the outer case should never be opened by the user. To ensure proper safe operation in demonstrations and performances, immediately discontinue use of this product if you notice or suspect that any part of the laser is not functioning properly. After any repair, service, or modification, this product must be certified by the manufacturer to comply with US Federal requirements for laser demonstration equipment. In case of any malfunction,

contact X-Laser or your dealer for an RMA number and we will repair the unit to bring it back into working operation and US Federal compliance.

Training and Qualification

In the United States, Class 3B and 4 laser products may only be used by a person or employees of an organization which holds a Laser Light Show Variance. All such persons must have adequate and appropriate laser operation and safety training, keep a copy of their variance with them at all performances, and keep appropriate safety logs and checklists. The variance holder must also file annual reports as required by the CDRH (FDA) and ensure that their variance is renewed prior to expiration. Copies of these forms, introductory training materials, and more may be found on the USB DRIVE enclosed with this product.

We strongly recommend that each user of an X-Laser product read "Safe Laser Display" literature published as ANSI Z136.1 and Z136.10. These and a wealth of laser safety information are available from www.rli.com and the Laser Institute of America. We also strongly recommend that proper safety equipment such as wavelength specific laser safety glasses be used during any times in which a technician or others could be exposed to laser radiation.

Excellent laser training is available from a number of private institutions such as RLI and we recommend that all of our users undertake it. Basic safety training is provided with this product but is NOT meant to be comprehensive. Please follow the enclosed instructions on the user USB drive.

Special Considerations for Outdoor Use

Do not ever, under any circumstances, allow laser beams to enter airspace except under conditions specifically approved by the FAA and any other applicable authorities. FAA approval is only ever granted for a specific case and under specific conditions for the specific timeframe outlined in an application filed by the operator. Contact X-Laser or a qualified Laser Safety Officer for guidance on performing uninterminated outdoor laser shows safely and legally. **Striking an aircraft with a laser beam, even if accidental, is dangerous and is a felony punishable by fines and jail time.**

We want you to have a wonderful experience with our products so that you can bring the thrill of professional laser light shows to your audiences. The safety procedures outlined in this manual should be easy to successfully implement in your shows and provide you with years of safe and profitable laser displays. Please contact us if you have any questions about how to safely and effectively use X-Laser products.

General Guidelines for Proper Usage

1. Always treat your laser with great care as some components are very fragile. While this product is designed to withstand the normal rigors of production use, drops or other severe impacts may cause internal misalignments requiring factory service or other serious internal damage. Care for it as you would a video projector.
2. Mercury-equipped X-Laser systems including the Skywriter HPX M-series are designed to work well with professional production lighting control systems. More basic control systems may not be able to present the capabilities of the Mercury control system in an intuitive or easy to use manner leading to a frustrating experience.
3. Always keep all factory supplied labels on the unit and visible. Never cover or disable the emission indicator on the front of the unit. The labels and indicators are all required for legal compliance.
4. The unit is supplied with black wrap foil to be used as beam blocks to prevent the laser from accidentally scanning into the audience area. This is provided separate from the fixture so that it can be applied, adjusted, and removed easily for mobile entertainment applications.
5. If this unit is to be permanently installed, you may permanently apply the foil to the outside of the unit. To apply, simply use thin strips of gaffer's tape or a heat safe glue for permanent installation. Using this foil is required for maximum safety and we recommend replacing the foil and/or tape at the first signs of wear. Replacement foil strips can be obtained very inexpensively through your X-Laser dealer.
6. Always maintain open space around all sides of the laser to facilitate airflow.
7. Always operate the laser in an ambient temperature of 50-90°F. Operation outside of this temperature range may result in failure or diminished operating life. Such failures are NOT covered under our manufacturer's warranty.
8. This unit is primarily intended for indoor use, but occasional outdoor use is acceptable. Treat this fixture like you would a video projector when using outdoors. Do not expose this fixture to rain or temperatures outside of a normal working range of 50-90°F/10-32°C, or direct sunlight. Do not store this product outdoors. While the Skywriter series is not fully weatherproof, the fixture is weather resistant, so outdoor use is acceptable. If the fixture will be used outdoors, we recommend that the fixture be covered, specifically over the back panel and top panel to protect the wired connections

Installation

You may hang or otherwise mount your new X-Laser product in any suitable orientation provided the requirements of this guide and all other applicable rules and regulations are observed. Before every show, verify that the programming and hard beam blocks are suitable for the application, especially if you have changed the orientation of the laser or if you are operating it in a new environment.

Safe Beam and Projection Height

Most US FDA variances require that all beams be kept at least 3 meters (10 feet) above any surface upon which your audience can stand. Refer to your variance for required vertical and lateral safety distances. Performers and trained personal MAY be exempt from these safety distances at the discretion of a qualified Laser Safety Officer who may be able to implement an alternative radiation safety plan.

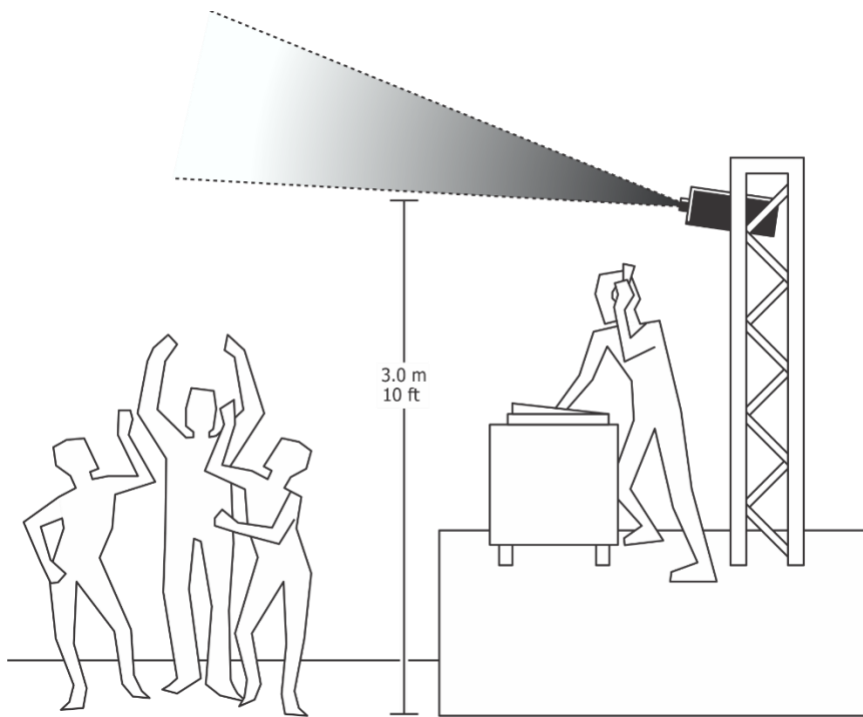

Example of a safe projection, 3 meters above the dance floor

Physical beam blocks

After your projection area has been set up in your laser controller, make sure to block off the laser aperture to make sure the projection area remains safe, even in the event of a laser or controller malfunction. You can do this using the physical block attached to the front of the laser (if equipped) as well as with “black wrap” cinefoil or black aluminum foil tape.

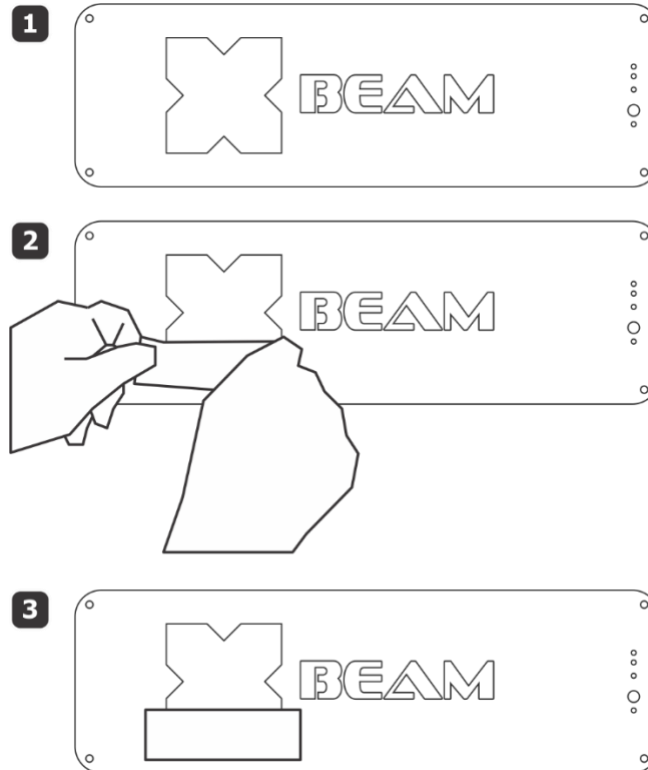

Operation

Before Powering up Your Projector

Laser beams may shoot in unexpected places during setup, so be sure that all areas which may be within the projection field of the laser are clear of people and flammable materials. Be prepared to immediately terminate the laser output if any laser is emitted in an unsafe direction.

Be sure the laser projector is safely and securely rigged, and not likely to be moved or dislodged by vibration or collision with any moving scenery, equipment, people, animals, etc.

Be sure you have at least one, but preferably two, reliable means of attenuating the laser beam such as an etherStop pendant, functioning DMX/Art-Net control, or the ability to quickly cut power to the projector. Mains power termination should only be considered a secondary safety system, not the primary means of attenuation.

Duty Cycle

The laser may be left powered on without projecting any laser content indefinitely, however over time this will result in the cooling fans, filters, and external heatsinks needing more frequent cleaning. For optimal maintenance intervals, power off the system when it will not be used for more than an hour or two. When operated within the specified temperature range, the laser may be operated continuously for up to four hours with no ill effect.

Laser Startup

To provide safe and reliable operation and meet the requirements of US Federal regulations and international standards, X-laser projectors generally require a multi-step startup procedure:

1. After power on, the laser starts in the “Startup” state.
2. If any key switches are not in the enabled position or any remote interlocks are open, the laser will enter the “Not Ready” state. The laser’s display will indicate the required action, for example “Turn Key” or “Interlock Open”
3. All key switches must be switched to the enabled position, all remote interlocks must be closed, and if the reset input is initially asserted, it must be released.
4. When these conditions are met, the laser will enter the “Ready” state and the emission indicator will flash briefly once every three seconds.
5. The reset input must be asserted, either by pressing the reset button on a remote pendant or by pressing the laser button  on the projector.
6. The laser will test its local emission indicator and then enter the “Emission Delay” state. The emission indicator will flash once per second during this time.
7. If all key switches and remote interlocks are kept in the closed state, the laser will enter the “Enabled” state after the emission delay time has expired. The emission indicator will be on continuously, and the laser will be ready to emit if a suitable control signal is applied.
8. If at any point a key switch or remote interlock is opened, the laser will immediately return to the “Not Ready” state.

The etherStop system

X-Laser's etherStop control interface combines network-based control (such as Art-net) and a remote E-stop interface into a single cable. The interface includes 10/100Mb Ethernet, a remote interlock loop, an emission signal, and a reset signal, all in a single CAT5 or CAT6 network cable. We recommend etherCON connectors and rugged CAT5 or better cables for best durability, but standard networking cables can be used for less demanding setups.

etherStop terminator

Every etherStop compatible laser projector ships with an etherStop terminator that may be used as a service plug. This terminator closes the etherStop interlock loop, but does not provide a reset signal.

The service plug is intended to be used during testing only and does not meet US federal requirements for a means of remote termination of laser output per 21CFR1040.10. When using the terminator as a service plug, physical access to the laser is required to reset the laser to initiate laser emission.



In almost all cases, we recommend that etherStop-equipped projectors be used with an etherStop pendant or a Nexus etherStop switch system (sold separately).

To use the terminator as a service plug for bench testing, connect the terminator to one of the two etherStop ports on the back of the laser. This will close the interlock loop. With the terminator installed, and the key switch in the enabled position, press the laser button  next to the LCD to reset the projector and enable laser emission.

Do NOT install the terminator in the laser when using an etherStop pendant or other remote stop system.

etherStop Pendant

etherStop connections

The etherStop pendant has 3 etherCon connectors. These provide connections for:

1. Network – this connector is for data input (Art-Net or SACN) from your control source
2. Laser - etherStop LASER control out (green connector). This connector carries the combined emergency stop signal, reset signal from the pendant itself and the Remote connector and the data injected from the Network connector. If the laser is being controlled through DMX or ILDA only and not using network data for laser control this will only carry the emergency stop and reset signals
3. Remote – this connector provides expansion to a secondary control location for additional safety if the show requires it. If no secondary control location is required, insert the etherStop terminator into this port. Otherwise, connect this port to the Laser port of the secondary control, and insert the terminator in the Remote port of the secondary control. A total of up to five pendants, including the primary pendant may be daisy chained in this manner.



Do NOT connect more than one pendant directly to a laser projector. When using more than one pendant, ALWAYS connect the second pendant to the Remote port of the first pendant.

etherStop interface



The front of the etherStop interface contains:

1. **BIG RED BUTTON** – Depress this button to emergency stop your laser. The button will latch in the down position when pressed, twist it clockwise to reset the switch.
2. **Reset button/Emission indicator** – The laser requires a reset signal to begin laser emission after startup or after an interlock has been opened. The emission indicator will illuminate or flash to indicate the state of the laser system. Refer to the “Laser Startup” section above for details on the startup sequence.
3. **Key switch** - This key switch is part of the remote interlock loop and must be actuated to permit emission from your laser.

Remove this key to prevent unauthorized operation if the control station must be left unattended.

The etherStop interface is only part of the laser projector’s interlock and safety system. In order to close the remote interlock loop and permit laser output, the following conditions **must** be met:

1. The key switch must be turned to the enabled position, if you cannot pull the key out of the switch it is in the enabled position.
2. The **BIG RED BUTTON** must be in the “up” position on all connected pendants.
3. The Laser port (green) on the etherStop pendant must be connected to the laser via either etherStop port on the laser.
4. The last pendant in the daisy chain must have an etherStop terminator installed in the Remote port
5. Once these conditions are met, the emission indicator will flash once every three seconds. Pressing the reset button will then cause the system to enter the Emission Delay state, and the emission indicator will flash once per second.
6. At the end of the Emission Delay period, if all interlocks remain satisfied, the emission indicator will illuminate solidly, and the system will be ready to emit when an appropriate control signal is provided.

The etherStop system can control up to 10 lasers “daisy chained” together. For larger systems or systems where chaining is not desirable, please contact us for more information on our Nexus line of etherStop hubs.

etherStop system examples

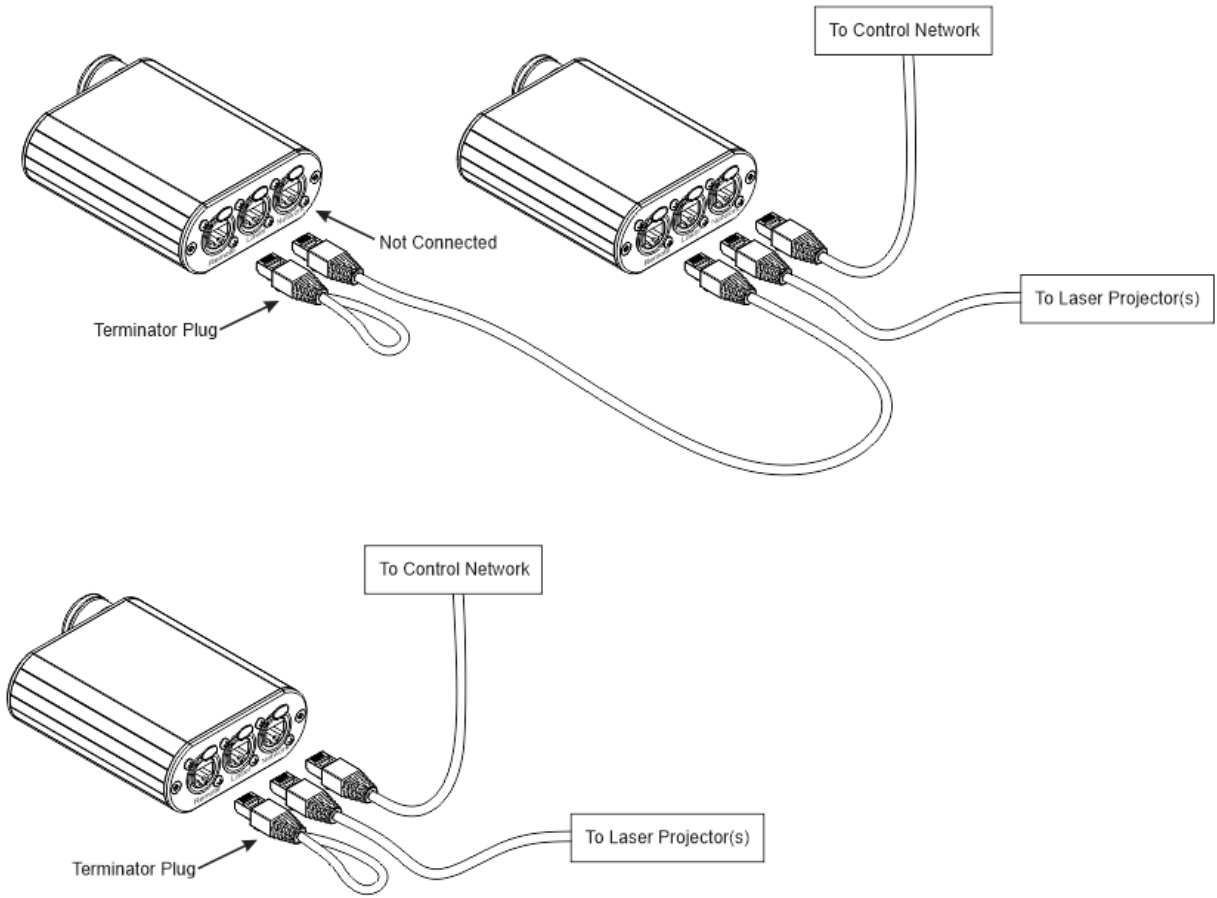

Other e-stop systems

Some users may already have other laser systems and prefer to wire their e-stop system to be compatible across all their projectors. Additionally separate remote relays and switches can be used in place of the terminator to integrate remote stop busses, door switches and more. For users who require such arrangements, example wiring is shown below.

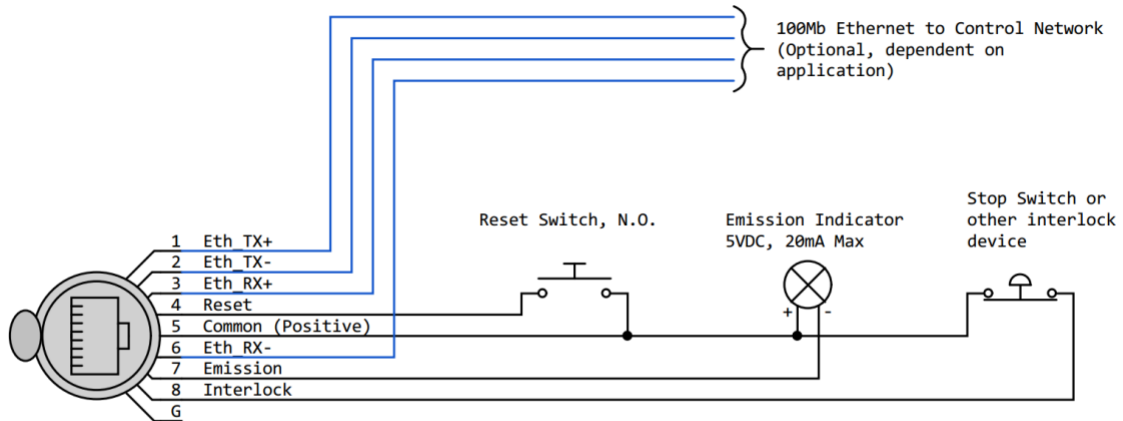

- Switches may be replaced by relays as required by the application.
- All switches or relays should be rated for 24V and specified for low signal operation.

While the etherStop interface has been designed with reasonable protections against miswiring, damage to the laser through improper use of the etherStop interface may be possible and is not covered under the warranty. X-Laser is unable to provide support for external E-stop systems implemented by others.

The Mercury Menu system

Lasers equipped with our Mercury laser control system have a large, full color LCD menu system to navigate all the available settings and options. This menu system is navigated using the 8 keypad buttons.



Directional buttons



Back button



Enter button



Menu button



Laser button

System Status Display

The System Status display is the default display and provides an “at a glance” view of the most critical information such as:

Ctrl: This is an indicator of the currently set control mode. This can be DMX, Art-Net or Manual

Status: This indicates the status of the control source. This may indicate:

Timeout! – A control packet has not been received within the timeout period

Too Slow - control packets are being received, but not frequently enough to meet the packet threshold

Ready - control packets are being received regularly

Universe: This indicates the Art-Net universe the laser has been set to, if in DMX mode this will read DMX, if in manual mode this will read MANUAL

Address: This indicates the address the laser projector has been set to if in DMX or Art-Net modes. If the projector is in Manual mode this will read MANUAL



Laser Status: This indicates the status of the laser's internal safety systems. Statuses include:

Enabled - The projector is capable of emitting laser when an appropriate control signal is sent

Turn Key – The key switch is in the disarmed position

Interlock Open – The system detects that the etherStop interface remote interlock loop is open (no etherStop pendant or compatible terminator connected, key switch not in the enabled position, or BIG RED BUTTON pressed)

Indicator Fail! - The emission indicator on the laser has failed. Per IEC60825 the emission indicator is failsafe, so emission is prohibited



Not Ready – The system is not ready to emit laser for some internal reason



Suspended – Emission has been suspended due to an internal laser fault or diagnostic state

Release Reset - the reset signal must be released before the laser will respond to the reset button being pressed

Press Reset – The projector is ready to emit, but has not had the etherStop reset triggered

Wait – The projector is in the Emission Delay state and will be ready to emit at the end of the Emission Delay period (ten seconds on most systems)

Additional status screens showing the status of the available control interfaces are available using the left  and right  arrow keys.

To access the Main Menu from the System Status screen, press the Menu  button. From the main menu, pressing the back  key will return to the status screen.

System Menu

The system menu includes frequently changed settings such as:

Personality The DMX personality of the system. Available options are:

1. Master only
2. 1X Basic Builder
3. 2X Basic Builder
4. 3X Basic Builder
5. 4X Basic Builder
6. 1X Advanced Builder
7. 2X Advanced Builder
8. 3X Advanced Builder
9. 4X Advanced Builder

These personalities are explained in depth in the Fixture Profile section of this manual.

- Control Source** Sets the control source to Manual, DMX or Art-Net
- DMX Timeout (ms)** The DMX timeout setting in milliseconds. Default is 100
- Art-Net timeout (ms)** The Art-Net timeout setting in milliseconds. Default is 2000
- Load Defaults** Resets the system to the factory defined default settings
- About** Important information about your system such as the model of laser, serial number of the Mercury interface and MAC address of the system

The DMX and Art-Net timeouts should be set to the minimum value that provides reliable operation. The system requires a continuous control signal to maintain output, and the loss of that control signal should result in termination of output as soon as possible, with the understanding that there is a minimum time required for reception of new control packets.

DMX Menu

The DMX menu allows you to set the projector's DMX receiving characteristics, such as:

- Address** The starting DMX address of the projector
- Packet Threshold** The packet threshold for receiving DMX, default is 30

Network Menu

This menu is where you access the network settings of this projector.

- IP Mode** Set the IP mode, at this time the only option is Static IP but this will likely change in a future release
- Static IP** Sets the static IP, the default is 10.0.0.1
- Subnet** Sets the subnet, the default is 255.0.0.0

Art-Net Menu

This is where the Art-Net specific settings of the projector are accessed.

- Mode** Sets the Art-Net mode as enabled or disabled
- Universe** Sets the Art-Net Universe the projector responds to
- Poll Reply Mode** Sets the poll reply mode, available options are:
 1. Limited broadcast (default)
 2. Unicast
 3. As Polled
 4. Broadcast
- Packet Threshold** Sets the packet threshold, the default is 4

X/Y Menu

Zoning your laser is one of the most important setup steps and this menu is essential to accurate and safe zoning. While many may choose to do all their zoning from the Master fixture via DMX or Art-Net, it's still essential to learn this menu.

- X Invert** Flips the projection along the X Axis, left to right
- Y Invert** Flips the projection along the Y Axis, top to bottom
- X/Y Swap** Switches the X and Y axis, this way a projector mounted at 90 degrees can maintain the same orientation as a projector mounted traditionally
- X/Y Ext. Control** This setting controls the X/Y size and position controls from the DMX or Art-Net Input. Available options are:
 1. Full – DMX/Art-Net control is enabled, and is not limited by the minimum and maximum values set in the X/Y Limits submenu
 2. Scale – DMX/Art-Net control is enabled, but the DMX values are scaled to the range between the minimum and maximum values set in the X/Y Limits submenu
 3. Limit – DMX/Art-Net control of scale and positions is enabled, but the DMX values are not permitted to go beyond the limits set in the X/Y Limits submenu
 4. Disable - DMX/Art-Net control of scale and position is disabled, and the size and position values from the X/Y submenu are used
- X Scale** Sets the X Scale from 1-256, with 1 being the minimum and 256 being the maximum. This scale setting is ignored when DMX/Art-Net control is enabled and X/Y Ext. Control is set to Full. The default is 128
- Y Scale** Sets the Y Scale from 1-256, with 1 being the minimum and 256 being the maximum. This scale setting is ignored when DMX/Art-Net control is enabled and X/Y Ext. Control is set to Full. The default is 128
- Y Offset** Sets the Y Offset from -100 to 100. This scale setting is ignored when DMX/Art-Net control is enabled and X/Y Ext. Control is set to Full. The default is 0
- X Offset** Sets the X Offset from -100 to 100. This scale setting is ignored when DMX/Art-Net control is enabled and X/Y Ext. Control is set to Full. The default is 0
- X/Y Limits** Sets the limits for Scale and Offset when X/Y Ext. Control is set to Scale or Limit

Colors Menu

The colors menu allows you to do basic color balancing across your projectors.

- Red Min** The minimum level of the Red laser source when there is any red laser commanded to be on
- Red Max** The maximum level of the Red laser source when there is any red laser commanded to be on
- Green Min** The minimum level of the Green laser source when there is any Green laser commanded to be on
- Green Max** The maximum level of the Green laser source when there is any Green laser commanded to be on
- Blue Min** The minimum level of the Blue laser source when there is any Blue laser commanded to be on
- Blue Max** The maximum level of the Blue laser source when there is any Blue laser commanded to be on
- Color 4 Min** The minimum level of the Color 4 laser source when there is any Color 4 laser commanded to be on, if the projector is so equipped
- Color 4 Max** The maximum level of the Color 4 laser source when there is any Color 4 laser commanded to be on, if the projector is so equipped
- Color 5 Min** The minimum level of the Color 5 laser source when there is any Color 5 laser commanded to be on, if the projector is so equipped
- Color 5 Max** The maximum level of the Color 5 laser source when there is any Color 5 laser commanded to be on, if the projector is so equipped
- Color 6 Min** The minimum level of the Color 6 laser source when there is any Color 6 laser commanded to be on, if the projector is so equipped
- Color 6 Max** The maximum level of the Color 6 laser source when there is any Color 6 laser commanded to be on, if the projector is so equipped

Display Menu

The display menu allows you to adjust the settings for the LCD display on your laser.

- Brightness** Sets the brightness from 1-10, 1 being the minimum and 10 the maximum
- Timeout** Sets the timeout for the LCD screen from 5 seconds to 10 minutes or to never turn off

Manual Operation Menu

The manual operation menu allows you to select the manual operation mode of the laser, typically used to enable ILDA input without the use of DMX or Art-Net. Available modes are:

- Fixture Disabled** Disables the laser projector from accepting any control inputs
- Builders Enabled** Not yet enabled
- Preset Mode** Not yet enabled
- External Input** Allows signal input from an external source, such as ILDA or FB4 (if equipped)

Mercury Menu



This menu grants access to some of the control parameters of the Mercury laser engine. Do not adjust these settings unless directed to by an X-Laser technician.

Content Menu

This menu allows you to see what content packs you have installed, if any, and to install new content packs as needed. The projector can store 2 separate content packs.



To install a new content pack, insert a USB drive into the USB port on the laser that has an X-Laser content file (*.XLC) on it, select content pack 1 or 2, then select Install and follow the on screen prompts.

Restoring settings

In rare cases, improper or corrupted settings may prevent the system from starting correctly or may cause other undesired operation. In this case, the default settings may be restored by holding the back  key down while the laser powers on. Keep the back  key pressed until the two status LEDs next to the LCD turn green and the system status screen is displayed, then release it.

System Update Menu

The system update menu is hidden from regular access. Be careful in the system update menu as it is possible to erase your content packs and settings.

The system update menu is accessed by holding the Menu  button down while the laser powers on. Keep the Menu  button pressed until the system update menu is displayed, then release it.

The system provides two software update storage slots. The primary slot is used to store the last installed update, and the backup slot may be used to hold an alternative software version in case the installed version must be reverted for any reason. Updates from USB are always installed via the primary update slot.

Exit	Return to main menu
System Info	Important information about your system such as the model of laser, serial number of the Mercury interface and MAC address of the system
Install update from USB	This allows you to update the firmware on your laser projector. Insert a USB drive into the USB port with the X-Laser firmware (*.XLB file) on it. Select this setting and follow the on screen prompts. Detailed instructions are included with all software update files.
Reinstall last update	Reinstalls the last update that was installed from USB
Install backup software	Reinstalls software stored in backup slot
Update backup	Loads software into backup slot, but does not install it
Clear Pending Tasks	This clears any requested actions and is useful in case of certain error conditions that may rarely occur in case of a corrupted update
Erase last update	Clears the update storage slot
Erase Backup	Erases the update stored in the backup slot
Erase Application	Erases the currently installed application. The bootloader and in most cases the settings are preserved, so the laser is not bricked, but will need to have application software installed before it becomes useful again. Unless you're a certified X-Laser technician, please don't do this

A video showing the update process and the latest firmware can be found at

<http://www.x-laser.com/mercurydownloads>

Remote Management and Configuration

Mercury-equipped laser systems can be managed and configured via RDM. Standard RDM Parameters such as DMX start address, personality, and device label can be accessed through any compliant RDM controller via the 5-pin DMX port, or via Art-Net. Additional configuration options are available that require custom, X-Laser-specific RDM parameters, which can be accessed using XLERATE, X-Laser's free companion software. XLERATE can connect to Mercury-equipped laser systems via a local network and configure all of the Laser's RDM-enabled properties, including all of their custom parameters. XLERATE can also discover and configure other RDM-enabled devices that are accessible via Art-Net. For more information or to download XLERATE, please see <https://x-laser.com/pages/xlerate>.

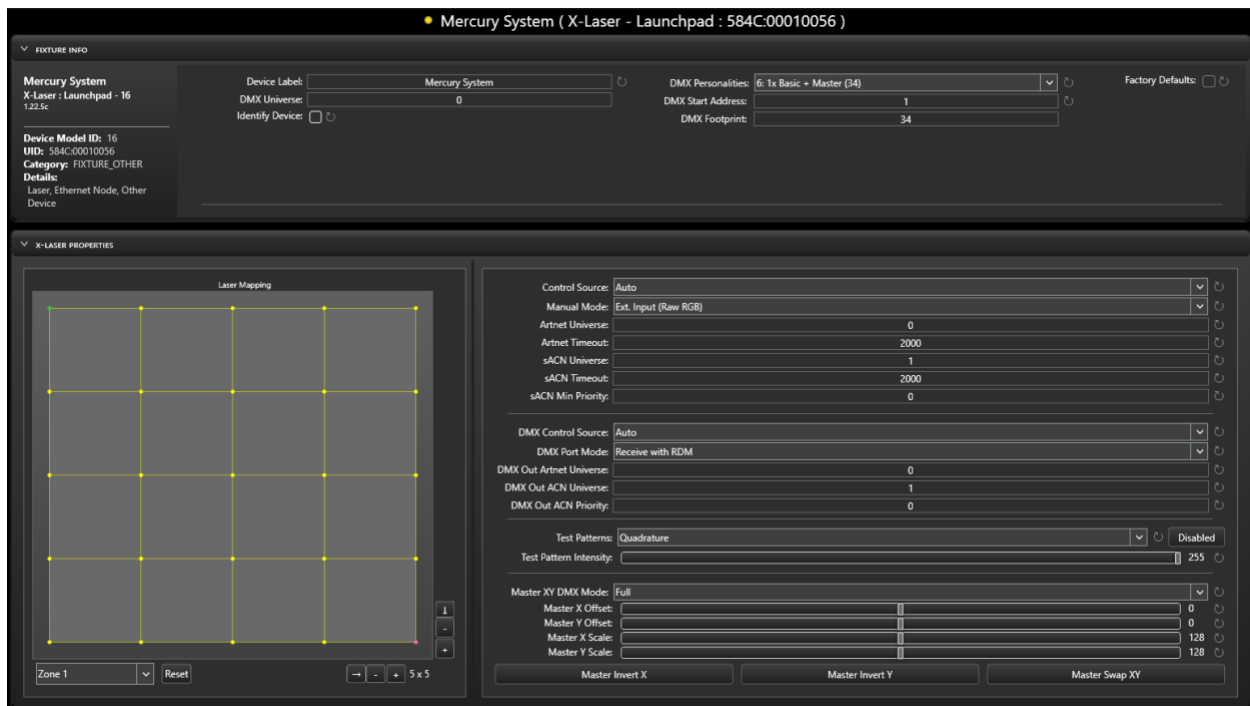

Previsualization

Because of the wide range of possible patterns that Mercury-equipped laser systems can create, these systems cannot be directly visualized like a typical moving light within a standard previsualization tool. Instead, XLERATE, X-Laser's free companion software, can be used to emulate Mercury-equipped laser systems and send the resulting laser data to many of the leading previsualization tools to be rendered along with your other lighting. XLERATE also features built-in 2D preview windows that can be used even without an external previsualization tool to preview and pre-program effects. For more information or to download XLERATE, please see <https://x-laser.com/pages/xlerate>.

Controlling your laser projector

Master and builders

The Mercury laser control system built into your Skywriter HPX M-5 was developed from the ground up as a new and uniquely powerful way to control laser projectors with DMX or Art-Net. With this novel

design, there's a new concept of how to set up the laser. We've broken up the laser control into parts we call the master and builders.

The **Master** is a block of six channels that control the overall projection area, intensity and mode (fixture disabled, external input, builders enabled). The external ILDA input and all builder-generated content is subject to the Master's size, position, and intensity controls, and once these controls are set nothing can go beyond them. Most users set up the Master when zoning their projectors, then park or freeze the Master fixture so that it cannot be modified during the show.

Builders are used to "build" up laser effects from a basic shape and several layers of available modifiers, including intensity, size, position, color effects, gobos, prisms, wave effects and motion effects. We have two different types of builders exposing different levels of complexity.

The **Basic Builder** is 28 channels and the type most users will want to start with. The basic builder provides control over:

1. Intensity
2. Gobos
3. Preset color macros
4. RGB1 and RGB2 for the color macros
5. Prisms with X/Y spacing and rotation
6. Geometric Post Group (see Geo Pre/Post for further explanation) which is similar to zoom, Pan/tilt and gobo rotation on a mover
7. Motion macros with speed and size, similar to an animation wheel

While the basic builder seems more limited than the advanced builder, its simplicity allows for an easier learning curve and faster programming, so it's a worthwhile place to start even for users who may eventually move to the advanced builders. Its simplicity makes it a very close analog to a moving light, and so the same programming concepts are easily applied. Additionally, it requires only a fraction of the DMX channels that the advanced builder consumes, and so is a good choice in situations where the number of available control parameters is limited. The basic builder is supported on all DMX consoles.

The **Advanced builder** is 85 channels and contains many more parameters for color, size, waves and motion effects. The advanced builder is extremely powerful but has a much steeper learning curve. When starting out with the advanced builders, we highly encourage you to check out our tutorial videos on youtube. The advanced builder offers control over:

1. Intensity
2. Gobos
3. In depth color functions including gradient type, gradient width, position and many more
4. RGB1 and RGB2 for the color effects
5. Geometric Pre and Post groups (see Geo Pre/Post for further explanation)
6. Prisms with X/Y Spacing and rotation
7. Two advanced wave modulation effect banks
8. Two motion effect banks

While the advanced builders are extremely capable, they are also much more complex to learn. Please check out our tutorials on youtube for further instruction on using advanced builders. Please note that Advanced Builders are NOT supported on all consoles. At this time Advanced Builders are only supported on Avolites Titan and MA Lighting GrandMA2 and dot2 consoles.

Whether basic or advanced, multiple builders can be layered over top of each other for more complex effects or for fast crossfades/bumps. Up to four builders of either type can be used simultaneously depending on the personality selected on the fixture.

DMX Control

This laser supports DMX-512/RDM (ANSI E1.11/E1.29) via standard 5-pin XLR connectors. To enable control by DMX:

1. Set **System > Control Source** to **DMX**, and provide a DMX control source, or use auto source selection.
2. Assign the DMX start address in **DMX > Address** to match how the laser is patched in your control system
3. Adjust additional parameters in the DMX menu as needed for reliable operation:
 - a. **Packet Threshold** determines how many valid DMX packets the system must receive before it will begin responding to DMX control.
 - b. **Timeout (ms)** determines how long the system will wait between valid DMX packets before terminating output. This should be set to the lowest value that provides reliable operation

sACN Control

This system supports Streaming ACN (ANSI E1.31) for the transport of DMX data over an Ethernet connection. To enable control via sACN:

1. Set **System > Control Source** to sACN and provide a Streaming ACN control source or use auto source selection.
2. Assign an sACN universe in **sACN > Universe** to match the universe your control system is transmitting
3. Assign the DMX start address in **DMX > Address** to match how the laser is patched in your control system
4. Adjust additional sACN parameters in the sACN menu as needed for reliable operation:
 - a. **Packet Threshold** determines how many valid sACN packets the system must receive before it will begin responding to sACN control.
 - b. **Timeout (ms)** determines how long the system will wait between valid sACN packets before terminating output. This should be set to the lowest value that provides reliable operation
 - c. **Minimum Priority** determines the minimum sACN packet priority the system will respond to. By default, sACN sources transmit at priority 100, but valid priority levels are 0-200 inclusive.
 - d. **Priority Time (ms)** determines how long the system will wait before looking for a lower-priority source if the current source stops transmitting

By default, the system will respond to the highest priority source transmitting on the assigned universe. If that source stops transmitting, the system will switch to the next highest priority source after Priority Time. This facilitates smooth fail-over between primary and backup sources with no additional equipment. If more than one source is detected transmitting at the highest priority on the assigned universe, the system will stop responding the sACN control until only one source is detected. During this condition, the system will indicate **Sources Exceeded** on the sACN Status Screen.

If necessary, a Minimum Priority can be set to prevent the system from responding to any source with a lower priority. This can be used to prevent sources transmitting at default priority from taking control of the lasers due to an error in universe assignment.

Most control systems will fall back to transmitting sACN DMX packets only once every one or two seconds unless universe data is actively changing, in which case the sACN Timeout must be set for 1000-2500ms. Improved safety and faster fail-over can be achieved by enabling continuous sACN output. Some control systems support this as a toggle option in their output configuration. On other systems continuous output can be achieved by assigning an unused dimmer or other device with a continuously running effect to the desired universe.

Art-Net Control

This system supports Art-Net 4 (v1.4) as developed by Artistic Licence for the transport of DMX data over an Ethernet connection. To enable control via Art-Net:

1. Set **System > Control Source** to Art-Net and provide an Art-Net control source or use auto source selection.
2. Assign an Art-Net universe in **Art-Net > Universe** to match the universe your control system is transmitting. Note that valid Art-Net universes are 0-32767, but some control systems will use the numbers 1-32768.

Note: canonically, Art-Net splits the universe up into "Net", "Sub-Net" and "Universe" segments. These correspond to bits 14-8, 7-4, and 3-0 of the 15-bit universe number. To convert from Art-Net notation to Numeric notation as used by most software and this system:

$$\text{UniverseNumber} = (\text{Net} \times 256) + (\text{SubNet} \times 16) + \text{Universe}$$

3. Assign the DMX start address in **DMX > Address** to match how the laser is patched in your control system
4. Adjust additional Art-Net parameters in the Art-Net menu as needed for reliable operation:
 - a. **Packet Threshold** determines how many valid sACN packets the system must receive before it will begin responding to sACN control.
 - b. **Timeout (ms)** determines how long the system will wait between valid sACN packets before terminating output. This should be set to the lowest value that provides reliable operation
 - c. **PollReply Mode** determines how the system transmits responses to ArtPoll queries.

Most control systems will fall back to transmitting Art-Net DMX packets only once every one or two seconds unless universe data is actively changing, in which case the Art-Net Timeout must be set for 1000-2500ms. Improved safety can be achieved by enabling continuous Art-net output. Some control systems support this as a toggle option in their output configuration. On other systems continuous output can be achieved by assigning an unused dimmer or other device with a continuously running effect to the desired universe.

Auto Source Selection

This system supports automatic control source selection among DMX, sACN, and Art-Net. To enable automatic source selection, set **System > Control Source** to **Auto**. In this mode, a direct DMX connection will override both Art-Net and sACN, and sACN will override Art-Net. In all cases, all control sources are subject to the parameters (timeout, packet threshold, etc) configured in their respective menus. Art-Net and sACN sources always use the universes assigned in their respective menus.

Personalities

The Skywriter HPX M-5, M-10, and M-20 models have 15 different operating personalities. All personalities consist of a set of “Master” channels followed by 1-4 “Advanced Builder” channel sets or 1-6 “Basic Builder” channel sets. Each of the Master, Basic Builder, and Advanced Builder channel sets are designed to be patched as individual fixtures in your control system. Master and Basic Builder profiles are available for most control systems. Advanced Builder profiles are available on select control systems that have the capacity to display the large number of unique channels.

<i>Personality</i>	<i>Channels used</i>
Master only	6 Channels
1X Advanced Builder	91 Channels (6 master + 85 per builder)
2X Advanced Builder	176 Channels (6 master + 85 per builder)
3X Advanced Builder	261 Channels (6 master + 85 per builder)
4X Advanced Builder	346 Channels (6 master + 85 per builder)
1X Basic Builder	34 Channels (6 master + 28 per builder)
2X Basic Builder	62 Channels (6 master + 28 per builder)
3X Basic Builder	90 Channels (6 master + 28 per builder)
4X Basic Builder	118 Channels (6 master + 28 per builder)
5X Basic Builder	146 Channels (6 master + 28 per builder)
6X Basic Builder	174 Channels (6 master + 28 per builder)
Simple 1X Basic Builder	28 Channels (28 per builder)
Simple 2X Basic Builder	56 Channels (28 per builder)
Simple 3X Basic Builder	84 Channels (28 per builder)
Simple 4X Basic Builder	112 Channels (28 per builder)

Control Groups

The Mercury laser control system in your Skywriter HPX M-5 laser is simplified by breaking the control up into groups relevant to different features of the system. These control groups are:

1. Master Group
2. Builder Main Group
3. Color Group
4. Intensity Effect Group
5. Prism Control Group
6. Geometric Pre Group (advanced builder only) and Geometric Post group
7. Motion Macro Group (basic builder only)
8. Wave Effect 1 group (advanced builder only)
9. Wave Effect 2 group (advanced builder only)
10. Motion Effect 1 group (advanced builder only)
11. Motion Effect 2 group (advanced builder only)

The *Master Group* is the entirety of the Master Fixture and consists of the Enable function, Master Maximum Intensity, Master X/Y scale and offset.

The *Builder Main Group* is where the gobo wheels and overall intensity controls are located in the basic and advanced builders. There are also a few reserved channels for future expansion. It's important to note the maximum intensity in this group will never exceed the Intensity set in the Master fixture.

The *Color Group* contains RGB1 and RGB2 color pickers in both builder modes, preset color macros in the basic builder and a wide range of color tools in the advanced builder. For more information on the different color effects possible with advanced builders, please visit www.x-laser.com/mercurycolorgroup

The *Intensity Effect group* is not yet active but will be pretty damn cool when it is.

The *Prism Control group* is where the digital prism and its parameters are accessed. At the time of this writing there are 11 different digital prisms built into the system. Additional channels control the X and Y spacing of the prisms and the rotation across the facets. The rotation parameter is an incremental rotation applied to each successive prism element. For example, if the prism inner rotation is set to 5°, the first element will be rotated 0°, the second 5°, the third 10°, and so on. To rotate the entire prism, select rotation or spin from the geometric post group. To rotate the individual facets of the prism, select rotation or spin from the geometric pre group.

The *geometric pre and post groups* are the largest departure from more traditional intelligent lighting fixtures. The basic builder only has access to the Geometric Post group, this provides access to X and Y scale (zoom), X and Y position (pan and tilt), Z rotation (gobo indexing) and Z Spin (gobo rotation). The "Post" refers to these parameters happening after the prism modifier. For example, with a 1x3 linear prism on a circle gobo, a Z spin would spin the entire array of circles.

The advanced builders also permit access to the Geometric Pre group, which might at first seem redundant, but when combined with the prism effects the Geometric Pre/Post controls enable some very sophisticated effects that are unparalleled on any moving head. Because the Geometric Pre group is calculated before the prisms, you can use it to move, scale, rotate or spin the individual facets of the prism. As an example, with a 1x3 linear prism with a triangle gobo, each of the triangles in the prism can

be made to rotate clockwise, while the whole prism rotates counter-clockwise. You can learn more about how this works and why it matters by visiting www.x-laser.com/mercury-advanced

The *Motion Macro group* provide access to a number of pre built motion effects in Basic Builder modes. The Macro Speed channel can be used to override the recorded speed of the macro to make the effect faster or slower, and the Macro Size channel can likewise be used to override the recorded magnitude of the motion effect. When these channels are at 0, the default recorded speed and size of the macro are used.

The *Wave Effect groups* provide two banks of waveform oscillators that can be applied to the projected image. These can control the angle, frequency, amplitude, phase and traverse speed of the waves as well as if they are applied pre or post prism, just like color effects and geometric parameters. This is an advanced feature that is best understood by visiting www.x-laser.com/mercury-advanced

While most modern lighting consoles have excellent, complex and feature rich effects and shape engines, Mercury does have two integrated *Motion Effect groups* that allow you to apply different movement types with control of the scale, speed and waveform as well as if they are applied pre or post just like wave effects. This is an advanced feature that is best understood by visiting www.x-laser.com/mercury-advanced

Correlation with moving lights

The Mercury laser control system was designed to be easily mapped to mimic a moving head light in some ways to allow use of the effects and shape engines in your console. These best analogues for mapping your laser projector to existing moving head effects are as follows:

Dimmer	<i>Builder Intensity</i>
Pan	<i>Geometric Post X Position</i>
Tilt	<i>Geometric Post Y Position</i>
Gobo 1	<i>Pattern</i>
Gobo 2	<i>Pattern Page</i>
Gobo Indexing	<i>Geometric Pre Z Rotation</i>
Gobo Rotation	<i>Geometric Pre Z Spin</i>
Prism	<i>Prism</i>
Prism Rotation	<i>Geometric Post Z Spin</i>
Color	<i>First RGB set in color effect group</i>
Zoom	<i>Geometric Post X Scale + Y Scale</i>
Beam Shutters	<i>Geometric Correction</i>

DMX Parameters

The Master channel block controls overall fixture function and final size and position of the projection area.

The Master Mode channel is used to enable or disable the fixture, and to switch the fixture between external input and builder modes.

In Fixture Disabled mode, the fixture is active but will not project any content. This mode can be used to immediately stop all output directly from the console.

External Input mode applies to fixtures equipped with an ILDA input, and in this mode the signal presented at that input is directly displayed by the fixture. In this mode the external input signal is subject to the Master size, position, and intensity controls.

In Builder mode, the fixture's Builder capabilities are enabled, and the fixture will project the content generated by the Builder(s).

Master - 6 channels

Channel	8/16 Bit	Function	Values				
			0-3	4-7	8-11	12-15	16-255
1	8 bit	Enable	0-3	4-7	8-11	12-15	16-255
*			<i>Fixture Disabled</i>	<i>External input</i>	<i>Reserved</i>	<i>Builders Enabled</i>	<i>Reserved</i>
2	8 bit	Intensity	0-255				
*			<i>0-100%</i>				
3	8 bit	X Scale**	0-127	128		129-255	
			<i>100% - 50%</i>	<i>50%</i>		<i>50% - 0%</i>	
4	8 bit	Y Scale**	0-127	128		129-255	
			<i>100% - 50%</i>	<i>50%</i>		<i>50% - 0%</i>	
5	8 bit	X Offset	0-127	128		129-255	
			<i>Left Offset</i>	<i>Center</i>		<i>Right offset</i>	
6	8 bit	Y Offset	0-127	128		129-255	
			<i>Downward Offset</i>	<i>Center</i>		<i>Upwards offset</i>	

* this channel must have a NON ZERO value to cause laser output

** Note that this behavior has changed as of firmware version 1.22.6. Prior firmware versions used a split range with DMX 128 being 0% size and 129-255 increasing again in size with the zone inverted. The inversion feature in the master scale channels was removed for ease of use with new freeform zoning tools.

Basic Builder - 28 channels used

Master must be patched to enable the basic Builder

Builder Main Group													
Channel	8/16 Bit	Function	Values										
1	8 bit	Output Routing	0-7	8-255									
			<i>Zones 1-8</i>	<i>Reserved</i>									
2	8 bit	Gobo Page	0-14	15-253	254	255							
			<i>Gobo pages</i>	<i>Reserved</i>	<i>Optimized test patterns</i>	<i>Non-optimized test patterns</i>							
3	8 bit	Gobo Selection	0-255	<i>Please note, there are 410 gobos at the time of this writing so pages are not full yet. Future gobos are being released with firmware updates</i>									
			<i>Gobo Patterns</i>										
4 *	8 bit	Intensity	0-255										
			<i>0-100%</i>										
5	8 bit	Reserved	0-255										
			<i>Reserved</i>										

Color Group												
Channel	8/16 Bit	Function	Values									
6	8 bit	Color Macro	0-255									
			<i>Various Macros</i>									
7	8 bit	Red 1	0-255									
			<i>0-100%</i>									
8	8 bit	Green 1	0-255									
			<i>0-100%</i>									
9	8 bit	Blue 1	0-255									
			<i>0-100%</i>									
10	8 bit	Red 2	0-255									
			<i>0-100%</i>									

11	8 bit	Green 2	0-255										
			<i>0-100%</i>										
12	8 bit	Blue 2	0-255										
			<i>0-100%</i>										

Intensity Effect Group (not yet active)

Channel	8/16 Bit	Function	Values											
13	8 bit	Reserved	0-255											
			<i>Reserved</i>											

Prism control group

Channel	8/16 Bit	Function	Values											
14	8 bit	Prism selection	0-51	52-255										
			<i>Prism Selection</i>	<i>Reserved</i>										
15	8 bit	X Spacing	0-127	128	129-255									
			<i>100% - 0%</i>	<i>0</i>	<i>0 - 100% Inverted</i>									
16	8 bit	Y Spacing	0-127	128	129-255									
			<i>100% - 0%</i>	<i>0</i>	<i>0 - 100% Inverted</i>									
17	8 bit	Facet Rotation	0-255											
			<i>0-360 degrees</i>											

Geometric Post group (applied after prism)

Channel	8/16 Bit	Function	Values										
18	8 bit	X Scale	0-127	128	129-255								
			<i>100% - 0%</i>	<i>0</i>	<i>0 - 100% Inverted</i>								
19	8 bit	Y Scale	0-127	128	129-255								
			<i>100% - 0%</i>	<i>0</i>	<i>0 - 100% Inverted</i>								
20/21 *	16 bit	X Position	0-127	128	129-255								
			<i>Left</i>	<i>Center</i>	<i>Right</i>								
22/23 *	16 bit	Y Position	0-127	128	129-255								
			<i>Left</i>	<i>Center</i>	<i>Right</i>								
24	8 bit	Z Rotation	0-255										
			<i>0-360 degrees</i>										
25	8 bit	Z Spin	0	1-127	128	128-255							
			<i>No spin zone</i>	<i>Forward speed</i>	<i>No spin zone</i>	<i>Reverse speed</i>							

Motion Macro group







Channel	8/16 Bit	Function	Values										
26	8 bit	Motion macro	0-255										
			<i>Various macros</i>										
27	8 bit	Speed	0	1-255									
			<i>Default</i>	<i>Min to Max</i>									
28	8 bit	Size	0	1-255									
			<i>Default</i>	<i>Min to Max</i>									

Advanced Builder - 85 channels used

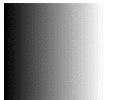
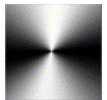
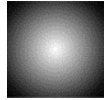
Master must be patched to enable the Advanced Builder

Builder Main Group												
Channel	8/16 Bit	Function	Values									
1	8 bit	Output Routing	0-7	8-255								
			<i>Zones 1-8</i>	<i>Reserved</i>								
2	8 bit	Gobo Page	0-14	15-253	254	255						
			<i>Gobo pages</i>	<i>Reserved</i>	<i>Optimized test patterns</i>	<i>Non-optimized test patterns</i>						
3	8 bit	Gobo Selection	0-255	<i>Please note, there are 410 gobos at the time of this writing so pages are not full yet. Future gobos are being released with firmware updates</i>								
			<i>Gobo Patterns</i>									
4 *	8 bit	Intensity	0-255									
			<i>0-100%</i>									
5	8 bit	Reserved	0-255									
			<i>Reserved</i>									
6	8 bit	Reserved	0-255									
			<i>Reserved</i>									
7	8 bit	Reserved	0-255									
			<i>Reserved</i>									
8	8 bit	Reserved	0-255									
			<i>Reserved</i>									

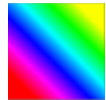
Color Group													
Channel	8/16 Bit	Function	Values										
9	8 bit	Color Function - Base	0	1	2	3	4-31						
			<i>No color override</i>	<i>Overall Color Override</i>	<i>H/S/I Manipulation</i>	<i>Pointwise gradient</i>	<i>Reserved</i>						
		Color Function - Pre 1 Position	32	33	34	35	36	37	38	39	40	41	42
			<i>No color override</i>	<i>Linear Gradient</i>	<i>Angular Gradient</i>	<i>Radial Gradient</i>	<i>Linear bands</i>	<i>Angular Bands</i>	<i>Radial Bands</i>	<i>Linear Rainbow</i>	<i>Linear Rainbow Reverse</i>	<i>Angular Rainbow</i>	<i>Angular Rainbow Reverse</i>
			43	44	45-63								
			<i>Radial Rainbow</i>	<i>Radial Rainbow reverse</i>	<i>Reserved</i>								
		Color Function - Pre 2 Position	64	65	66	67	68	69	70	71	72	73	74
			<i>No color override</i>	<i>Linear Gradient</i>	<i>Angular Gradient</i>	<i>Radial Gradient</i>	<i>Linear bands</i>	<i>Angular Bands</i>	<i>Radial Bands</i>	<i>Linear Rainbow</i>	<i>Linear Rainbow Reverse</i>	<i>Angular Rainbow</i>	<i>Angular Rainbow Reverse</i>
			75	76	77-96								
			<i>Radial Rainbow</i>	<i>Radial Rainbow reverse</i>	<i>Reserved</i>								
		Color Function - Mid 1 Position	97	98	99	100	101	102	103	104	105	106	107
			<i>No color override</i>	<i>Linear Gradient</i>	<i>Angular Gradient</i>	<i>Radial Gradient</i>	<i>Linear bands</i>	<i>Angular Bands</i>	<i>Radial Bands</i>	<i>Linear Rainbow</i>	<i>Linear Rainbow Reverse</i>	<i>Angular Rainbow</i>	<i>Angular Rainbow Reverse</i>
			108	109	110-127								
			<i>Radial Rainbow</i>	<i>Radial Rainbow reverse</i>	<i>Reserved</i>								
		Color Function - Mid 3 Position	128	129	130	131	132	133	134	135	136	137	138
			<i>No color override</i>	<i>Linear Gradient</i>	<i>Angular Gradient</i>	<i>Radial Gradient</i>	<i>Linear bands</i>	<i>Angular Bands</i>	<i>Radial Bands</i>	<i>Linear Rainbow</i>	<i>Linear Rainbow Reverse</i>	<i>Angular Rainbow</i>	<i>Angular Rainbow Reverse</i>
			139	140	141-159								
			<i>Radial Rainbow</i>	<i>Radial Rainbow reverse</i>	<i>Reserved</i>								
		Color Function - Post Position	160	161	162	163	164	165	166	167	168	169	170
			<i>No color override</i>	<i>Linear Gradient</i>	<i>Angular Gradient</i>	<i>Radial Gradient</i>	<i>Linear bands</i>	<i>Angular Bands</i>	<i>Radial Bands</i>	<i>Linear Rainbow</i>	<i>Linear Rainbow Reverse</i>	<i>Angular Rainbow</i>	<i>Angular Rainbow Reverse</i>
171	172		173-255										

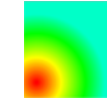
			<i>Radial Rainbow</i>	<i>Radial Rainbow reverse</i>	<i>Reserved</i>	<i>The Post position applies color effects after all other geometric, wave and motion effects. This allows your color effect to act as an overlay that you can move your beams through to change their color based on their position</i>							
Color mode examples													
			<i>Linear Gradient</i>	<i>Angular Gradient</i>	<i>Radial Gradient</i>	<i>Linear bands</i>	<i>Angular Bands</i>	<i>Radial Bands</i>	<i>Linear Rainbow</i>	<i>Angular Rainbow</i>	<i>Radial Rainbow</i>		
Color parameter note - Parameters change function based on color effect mode selection													
10	8 bit	Color Parameter 1	H/S/I Manipulation	0-255		Linear Gradients and rainbows	0-255		Angular, Radial Gradients and Bands	0	1-255		
				<i>Hue Offset</i>				<i>Angle: 0-360</i>			<i>Center</i>	<i>Left to right offset</i>	
11	8 bit	Color Parameter 2	H/S/I Manipulation	0-255					Angular, Radial Gradients and Bands	0	1-255		
				<i>Saturation Offset</i>						<i>Center</i>	<i>Bottom to Top</i>		
12	8 bit	Color Parameter 3	H/S/I Manipulation	0-255		Linear, Angular and Radial Bands	0	1-255					
				<i>Intensity Offset</i>				<i>Default Width</i>	<i>Band 1 width Min to Max</i>				
13	8 bit	Color Parameter 4	Angular Gradient and Rainbow	0-255		Linear, Angular and Radial Bands	0	1-255					
				<i>Repeat 1 to many</i>				<i>Default Width</i>	<i>Band 2 width Min to Max</i>				
14	8 bit	Color Parameter 5	All gradients, bands and rainbows	0-255									
				<i>Offset 0-100%</i>									
15	8 bit	Color Parameter 6	All Modes	0-255									
				<i>Fade Width 0-100%</i>									
16	8 bit	Red 1	0-255										
			<i>0-100%</i>										
17	8 bit	Green 1	0-255										
			<i>0-100%</i>										
18	8 bit	Blue 1	0-255										
			<i>0-100%</i>										
19	8 bit	Red 2	0-255										
			<i>0-100%</i>										
20	8 bit	Green 2	0-255										
			<i>0-100%</i>										
21	8 bit	Blue 2	0-255										
			<i>0-100%</i>										

Intensity Effect Group (not yet active)													
Channel	8/16 Bit	Function	Values										
22	8 bit	Reserved	0-255										
			<i>Reserved</i>										
23	8 bit	Reserved	0-255										
			<i>Reserved</i>										
24	8 bit	Reserved	0-255										
			<i>Reserved</i>										
25	8 bit	Reserved	0-255										
			<i>Reserved</i>										
26	8 bit	Reserved	0-255										
			<i>Reserved</i>										
27	8 bit	Reserved	0-255										
			<i>Reserved</i>										
28	8 bit	Reserved	0-255										
			<i>Reserved</i>										

Geometric Pre group (applied before prism)													
Channel	8/16 Bit	Function	Values										
29	8 bit	X Scale	0-127	128	129-255								
			<i>100% - 0%</i>	<i>0</i>	<i>0 - 100% Inverted</i>								
30	8 bit	X Scale	0-127	128	129-255								
			<i>100% - 0%</i>	<i>0</i>	<i>0 - 100% Inverted</i>								
31/32 *	16 bit	X Position	0-127	128	129-255								
			<i>Left</i>	<i>Center</i>	<i>Right</i>								
33/34 *	16 bit	Y Position	0-127	128	129-255								
			<i>Left</i>	<i>Center</i>	<i>Right</i>								
35	8 bit	Z Rotation	0-255										
			<i>0-360 degrees</i>										
36	8 bit	Z Spin	0	1-127	128	128-255							
			<i>No spin zone</i>	<i>Forward speed</i>	<i>No spin zone</i>	<i>Reverse speed</i>							

Prism control group												
Channel	8/16 Bit	Function	Values									
37	8 bit	Prism selection	0-51	52-255								
			<i>Prism Selection</i>	<i>Reserved</i>								
38	8 bit	X Spacing	0-127	128	129-255							
			<i>100% - 0%</i>	<i>0</i>	<i>0 - 100% Inverted</i>							
39	8 bit	Y Spacing	0-127	128	129-255							
			<i>100% - 0%</i>	<i>0</i>	<i>0 - 100% Inverted</i>							
40	8 bit	Facet Rotation	0-255									
			<i>0-360 degrees</i>									

Geometric Post group (applied after prism)												
Channel	8/16 Bit	Function	Values									
41	8 bit	X Scale	0-127	128	129-255							
			<i>100% - 0%</i>	<i>0</i>	<i>0 - 100% Inverted</i>							
42	8 bit	X Scale	0-127	128	129-255							
			<i>100% - 0%</i>	<i>0</i>	<i>0 - 100% Inverted</i>							
43/44 *	16 bit	X Position	0-127	128	129-255							
			<i>Left</i>	<i>Center</i>	<i>Right</i>							
45/46 *	16 bit	Y Position	0-127	128	129-255							
			<i>Left</i>	<i>Center</i>	<i>Right</i>							
47	8 bit	Z Rotation	0-255									
			<i>0-360 degrees</i>									
48	8 bit	Z Spin	0	1-127	128	128-255						
			<i>No spin zone</i>	<i>Forward speed</i>	<i>No spin zone</i>	<i>Reverse speed</i>						

Wave Effect 1 Group												
Channel	8/16 Bit	Function	Values									

49	8 bit	Wave Effect - Pre position	0	1	2	3	4	5	6-10	11	12	13	14		
			<i>No effect</i>	<i>Linear Sine</i>	<i>Linear Ramp</i>	<i>Linear Ramp Reverse</i>	<i>Linear Triangle</i>	<i>Linear Square Wave</i>	<i>Reserved</i>	<i>Radial Sine</i>	<i>Radial Ramp</i>	<i>Radial Ramp Reverse</i>	<i>Radial Triangle</i>		
			15	16-31											
		<i>Radial Square</i>	<i>Reserved</i>												
		Wave Effect - Mid position	32	33	34	35	36	37	38-42	43	44	45	46		
			<i>No effect</i>	<i>Linear Sine</i>	<i>Linear Ramp</i>	<i>Linear Ramp Reverse</i>	<i>Linear Triangle</i>	<i>Linear Square Wave</i>	<i>Reserved</i>	<i>Radial Sine</i>	<i>Radial Ramp</i>	<i>Radial Ramp Reverse</i>	<i>Radial Triangle</i>		
	47		48-63												
	Wave Effect - Post position	64	65	66	67	68	69	66-70	71	72	73	74			
		<i>No effect</i>	<i>Linear Sine</i>	<i>Linear Ramp</i>	<i>Linear Ramp Reverse</i>	<i>Linear Triangle</i>	<i>Linear Square Wave</i>	<i>Reserved</i>	<i>Radial Sine</i>	<i>Radial Ramp</i>	<i>Radial Ramp Reverse</i>	<i>Radial Triangle</i>			
		75	76-255												
	50	8 bit	Wave Angle	0-255											
				<i>0-360 degrees</i>											
51	8 bit	Wavelength	0-255												
			<i>Min to Max</i>												
52	8 bit	Amplitude	0-255												
			<i>Min to Max</i>												
53	8 bit	Phase	0-255												
			<i>0-360 degrees</i>												
54	8 bit	Traverse Speed	0	1-127	128-255										
			<i>Stopped</i>	<i>Forward speed</i>	<i>Reverse speed</i>										

Wave Effect 2 Group													
Channel	8/16 Bit	Function	Values										
55	8 bit		0	1	2	3	4	5	6-10	11	12	13	14

		Wave Effect - Pre position	<i>No effect</i>	<i>Linear Sine</i>	<i>Linear Ramp</i>	<i>Linear Ramp Reverse</i>	<i>Linear Triangle</i>	<i>Linear Square Wave</i>	<i>Reserved</i>	<i>Radial Sine</i>	<i>Radial Ramp</i>	<i>Radial Ramp Reverse</i>	<i>Radial Triangle</i>
			15	16-31									
			<i>Radial Square</i>	<i>Reserved</i>									
		Wave Effect - Mid position	32	33	34	35	36	37	38-42	43	44	45	46
			<i>No effect</i>	<i>Linear Sine</i>	<i>Linear Ramp</i>	<i>Linear Ramp Reverse</i>	<i>Linear Triangle</i>	<i>Linear Square Wave</i>	<i>Reserved</i>	<i>Radial Sine</i>	<i>Radial Ramp</i>	<i>Radial Ramp Reverse</i>	<i>Radial Triangle</i>
			47	48-63									
			<i>Radial Square</i>	<i>Reserved</i>									
		Wave Effect - Post position	64	65	66	67	68	69	70-74	75	76	77	78
			<i>No effect</i>	<i>Linear Sine</i>	<i>Linear Ramp</i>	<i>Linear Ramp Reverse</i>	<i>Linear Triangle</i>	<i>Linear Square Wave</i>	<i>Reserved</i>	<i>Radial Sine</i>	<i>Radial Ramp</i>	<i>Radial Ramp Reverse</i>	<i>Radial Triangle</i>
			79	80-255									
			<i>Radial Square</i>	<i>Reserved</i>									
56	8 bit	Wave Angle	0-255										
			<i>0-360 degrees</i>										
57	8 bit	Wavelength	0-255										
			<i>Min to Max</i>										
58	8 bit	Amplitude	0-255										
			<i>Min to Max</i>										
59	8 bit	Phase	0-255										
			<i>0-360 degrees</i>										
60	8 bit	Traverse Speed	0	1-127	128-255								
			<i>Stopped</i>	<i>Forward speed</i>	<i>Reverse speed</i>								

Motion Effect 1 Group												
Channel	8/16 Bit	Function	Values									
61	8 bit		0	1	2	3	4	5	6	7-31		

		Motion Effect - Pre position	<i>No effect</i>	<i>Elliptical Orbit</i>	<i>Elliptical Orbit and Rotate</i>	<i>Linear Scroll</i>	<i>Linear Ping Pong</i>	<i>Triangle Orbit</i>	<i>Square Orbit</i>	<i>Reserved</i>			
		Motion Effect - Mid position	32	33	34	35	36	37	38	39-63			
			<i>No effect</i>	<i>Elliptical Orbit</i>	<i>Elliptical Orbit and Rotate</i>	<i>Linear Scroll</i>	<i>Linear Ping Pong</i>	<i>Triangle Orbit</i>	<i>Square Orbit</i>	<i>Reserved</i>			
		Motion Effect - Post position	64	65	66	67	68	69	70	71-255			
			<i>No effect</i>	<i>Elliptical Orbit</i>	<i>Elliptical Orbit and Rotate</i>	<i>Linear Scroll</i>	<i>Linear Ping Pong</i>	<i>Triangle Orbit</i>	<i>Square Orbit</i>	<i>Reserved</i>			
62	8 bit	Motion Angle	0-255										
			<i>0-360 degrees</i>										
63	8 bit	X Scale	0-255	<i>Scale must be non 0 on one or both axes for movement effects to function</i>									
			<i>Min to Max</i>										
64	8 bit	Y Scale	0-255	<i>Scale must be non 0 on one or both axes for movement effects to function</i>									
			<i>Min to Max</i>										
65	8 bit	Dwell Time	0-255										
			<i>Min to Max</i>										
66	8 bit	Phase	0-255										
			<i>0-360 degrees</i>										
67	8 bit	Traverse Speed	0	1-127	128-255	<i>Traverse speed must be non 0 for movement effects to function</i>							
			<i>Stopped</i>	<i>Forward speed</i>	<i>Reverse speed</i>								

Motion Effect 1 Group												
Channel	8/16 Bit	Function	Values									
68	8 bit		0	1	2	3	4	5	6	7-31		

		Motion Effect - Pre position	No effect	Elliptical Orbit	Elliptical Orbit and Rotate	Linear Scroll	Linear Ping Pong	Triangle Orbit	Square Orbit	Reserved			
		Motion Effect - Mid position	32	33	34	35	36	37	38	39-63			
		Motion Effect - Post position	No effect	Elliptical Orbit	Elliptical Orbit and Rotate	Linear Scroll	Linear Ping Pong	Triangle Orbit	Square Orbit	Reserved			
		Motion Effect - Post position	64	65	66	67	68	69	70	71-255			
		Motion Effect - Post position	No effect	Elliptical Orbit	Elliptical Orbit and Rotate	Linear Scroll	Linear Ping Pong	Triangle Orbit	Square Orbit	Reserved			
69	8 bit	Motion Angle	0-255										
			0-360 degrees										
70	8 bit	X Scale	0-255	Scale must be non 0 on one or both axes for movement effects to function									
			Min to Max										
71	8 bit	Y Scale	0-255	Scale must be non 0 on one or both axes for movement effects to function									
			Min to Max										
72	8 bit	Dwell Time	0-255										
			Min to Max										
73	8 bit	Phase	0-255										
			0-360 degrees										
74	8 bit	Traverse Speed	0	1-127	128-255	Traverse speed must be non 0 for movement effects to function							
			Stopped	Forward speed	Reverse speed								

Presets Group (not yet active)												
Channel	8/16 Bit	Function	Values									
75	8 bit	Control	0-255									
			Reserved									
76	8 bit	Select	0-255									
			Reserved									

Geometric Correction Group												
Channel	8/16 Bit	Function	Values									
77	8 bit	Control	0-255									
			Reserved									

78	8 bit	Top Left X	0-127	128	129-255								
			<i>Left</i>	<i>Center</i>	<i>Right</i>								
79	8 bit	Top Left Y	0-127	128	129-255								
			<i>Top</i>	<i>Center</i>	<i>Bottom</i>								
80	8 bit	Top Right X	0-127	128	129-255								
			<i>Right</i>	<i>Center</i>	<i>Left</i>								
81	8 bit	Top Right Y	0-127	128	129-255								
			<i>Top</i>	<i>Center</i>	<i>Bottom</i>								
82	8 bit	Bottom Left X	0-127	128	129-255								
			<i>Left</i>	<i>Center</i>	<i>Right</i>								
83	8 bit	Bottom Left Y	0-127	128	129-255								
			<i>Bottom</i>	<i>Center</i>	<i>Top</i>								
84	8 bit	Bottom Right X	0-127	128	129-255								
			<i>Right</i>	<i>Center</i>	<i>Left</i>								
85	8 bit	Bottom Right Y	0-127	128	129-255								
			<i>Bottom</i>	<i>Center</i>	<i>Top</i>								

Gobo Guide

Your laser projector has over 400 digital gobos already loaded, with more to come in future firmware updates. Here's a quick guide to how they are organized:

Page 1 – Circles		Page 2 - Lines		Page 3 – Dangerous Curves	
Gobo	Gobo Name	Gobo	Gobo Name	Gobo	Gobo Name
1	circle	1	line	1	1 coil spiral
2	RGB circle	2	Big line	2	2 coil spiral
3	3 spine circle	3	big line with accents	3	3 coil spiral
4	4 spine circle	4	2 spine line	4	4 coil spiral
5	6 spine circle	5	3 spine line	5	5 coil spiral
6	1 point in circle	6	5 spine line	6	3 broken arcs
7	color 1 point in circle	7	a big fan	7	6 broken arcs
8	color 3 points in circle	8	V	8	simple arc
9	color 6 points in circle	9	color V	9	parentheses
10	fading circle	10	spine V	10	sliced circle
11	fading quadrant circle	11	dense spine v	11	2 arcs
12	segmented circle	12	broken V	12	concave square
13	segmented circle with spines	13	N	13	the downward spiral
14	2 cocentric circles	14	Broken N	14	color downward spiral
15	color 2 circles	15	3 lines	15	now in stereo
16	3 cocentric circles	16	3 spine lines	16	color now in stereo
17	RGB 3 cocentric circles 1	17	120 degree lines	17	squiggles
18	RGB 3 cocentric circles 2	18	RGB 120 degree lines	18	color squiggles
19	RGB 3 cocentric circles 3	19	power 3	19	feeling a little wavy
20	3 circles	20	big +	20	feelin pretty wavy
21	RGB 3 circles	21	color big +	21	feeling really wavy
22	traffic light	22	X	22	sproing
23	4 circles	23	color X	23	color sproing
24	color 4 circles	24	color X 2	24	light mess
25	Eclipse	25	RGB X	25	medium mess
26	shrinking circles	26	spine X	26	dense mess
27	olympic rings	27	XXX	27	DNA
		28	5 lines	28	fat swirl
		29	5 color lines	29	dangerous curves sign
		30	lattice		
		31	RGB lattice		
		32	pick up sticks		
		33	tic tac toe grid		
		34	square wave		
		35	ramp wave		
		36	offset cross		
		37	brackets		

Page 4 – Triangles		Page 5 - Squares		Page 6 – Other Polygons	
Gobo	Gobo Name	Gobo	Gobo Name	Gobo	Gobo Name
1	triangle	1	square	1	4 point star
2	big triangle	2	4 spine square	2	8 spine star
3	1 point in triangle	3	8 spine square	3	5 point star
4	concave triangle	4	fading quadrant square	4	10 spine star
5	3 spine triangle	5	2 cocentric boxes	5	6 point star
6	6 spine triangle	6	color 2 cocentric boxes	6	12 spine star
7	2 cocentric triangles	7	double diamond	7	7 point star
8	color 2 cocentric triangles	8	color double diamond	8	14 spine star
9	inverted 2 cocentric triangles	9	squarepocalypse	9	8 point star
10	color inverted 2 cocentric triangles	10	squareception	10	16 spine star
11	power triangle	11	square cascade	11	9 point star
12	hourglass	12	3 squares	12	18 spine star
13	triforce	13	2 not squares	13	10 point star
14	RGB triforce	14	segmented square	14	20 spine star
		15	breakup square	15	pentagon
		16	looking into the box	16	5 spine pentagon
				17	hexagon
				18	6 spine hexagon
				19	septagon
				20	7 spine septagon
				21	octagon
				22	8 spine octagon
				23	nonagon
				24	9 spine nonagon
				25	decagon
				26	10 spine decagon
				27	nested hexagons
				28	nested hexagons 2
				29	hexagonal hallway

Page 7 - Points		Page 8 – Abstract Building Blocks		Page 9 - Mixed	
Gobo	Gobo Name	Gobo	Gobo Name	Gobo	Gobo Name
1	1 point	1	Shredder	1	IO
2	3 point line	2	Hex C	2	Power
3	4 point line	3	broken spiral	3	IOI
4	5 point line	4	color warp	4	deathly hallows
5	6 point line	5	sickle circle	5	circle and square 1
6	7 point line	6	shards	6	circle and square 2
7	8 point line	7	shards 2	7	circle and square 3
8	9 point line	8	shards 3	8	circle and square 4
9	10 point line	9	shards 4	9	circle and square 5
10	16 point line	10	spaghetti	10	circle and triangles 1
11	point pentagon	11	gradient spaghetti	11	circle and triangles 2













	(Page 7 – Points continued)		(Page 8 – Abstract building blocks continued)		(Page 9 – Mixed continued)
12	point hexagon			12	circle and triangles 3
13	point septagon	12	big wave	13	Circle and a squiggle
14	point octagon	13	starting to unravel	14	circle and squiggles
15	point nonagon	14	infinitely broken	15	bisected circle
16	point decagon	15	I don't know what to call this one	16	circle with two lines
17	light point circle			17	circle with three lines
18	RGB light point circle	16	feathers	18	copper core
19	medium point circle	17	art	19	ferrite core
20	RGB medium point circle	18	abstract laundry pod	20	2 half circles
21	dense point circle	19	crumpled triangle	21	wifi
22	RGB Dense point circle	20	polar opposites	22	circle and 120 degree lines
23	light point triangle	21	bad hair	23	color circle and 120 degree lines
24	RGB light point triangle			24	triangle and 120 degree lines
25	medium point triangle			25	color triangle and 120 degree lines
26	RGB medium point triangle			26	DMX
27	dense point triangle			27	aperture
28	RGB Dense point triangle			28	throwing star
29	light point square			29	spiral star
30	RGB light point square			30	cracked square
31	medium point square			31	jack
32	RGB medium point square			32	stack of pennies
33	dense point square			33	peace
34	RGB dense point square				
35	light point array				
36	medium point array				
37	dense point array				
38	RGB dense point array				
39	light point burst				
40	medium point burst				
41	dense point burst				
42	light disordered point burst				
43	medium disordered point burst				
44	dense disordered point burst				
45	point cascade				

Page 10 – Alpha		Page 11 – Mike Dunn		Page 12 – Misc continued	
Gobo	Gobo Name	Gobo	Gobo Name	Gobo	Gobo Name
1	ALPHA A	1-60	Various awesome gobos designed by award winning Laser artist Mike Dunn www.firstlight-laser.com	21	Chevrons
2	ALPHA B			22	Arrow
3	ALPHA C			23	Ghost
4	ALPHA D			24	Invader
5	ALPHA E			25	animal trap
6	ALPHA F			26	cursor
7	ALPHA G			27	3D box
8	ALPHA H			28	notched wheel
9	ALPHA I			29	a maze ing
10	ALPHA J			30	icicle
11	ALPHA K			31	star of bethlehem
12	ALPHA L			32	shooting star
13	ALPHA M			33	the more you know
14	ALPHA N			34	puzzle piece
15	ALPHA O			Page 12 – Misc	
16	ALPHA P	Gobo	Gobo Name	36	Heart
17	ALPHA Q	1	sunrise	37	Spiderweb
18	ALPHA R	2	CASH	38	tetris1
19	ALPHA S	3	circuit traces	39	tetris2
20	ALPHA T	4	clock hour hand	40	tetris3
21	ALPHA U	5	clock minute hand	41	tetris4
22	ALPHA V	6	clock second hand	42	tetris5
23	ALPHA W	7	lightning	43	tetris6
24	ALPHA X	8	prism	44	tetris7
25	ALPHA Y	9	splat	45	bright idea
26	ALPHA Z	10	pac person	46	Quackers
27	ALPHA #	11	star eyed	47	Penrose
28	ALPHA @	12	adam can't draw	48	Long road ahead
29	ALPHA !	13	laser warning		
30	ALPHA %	14	Mr yuck		
31	ALPHA &	15	fallout		
32	ALPHA JUMP	16	the eye		
33	ALPHA PARTY	17	red eye		
34	ALPHA LASERS	18	5 stars		
35	ALPHA PROM	19	sunflower		
36	HAPPY BIRTHDAY	20	Remulak		
37	CONGRATUALTIONS				
38	ALPHA 2018				
39	ALPHA 2019				
40	ALPHA 2020				
41	ALPHA X-LASER				
42	ALPHA SPACE				

**Note that DMX values begin at 0, so a DMX value of 0 will select gobo 1 on a page, DMX1:Gobo2, etc*

Prism Modes

Your Mercury equipped laser comes with 12 digital prisms. You can also adjust the X and Y spacing on these prisms and rotate the segments for an even wider range of looks.

DMX Channel Value	Prism type	Example
0-3	None	
4-7	1x2	
8-11	1x3	
12-15	1x4	
16-19	1x5	
20-23	1x6	
24-27	3x triangular	
28-31	2x2 square	
32-35	5x pentagon	
36-39	6x hexagon	
40-43	2x3	
44-47	2x3	
48-51	2x2+1	

Basic builder color presets

For ease of operation there are many color presets built for use with the basic builder modes. Please note that these are presets for the color effects, to use these presets you still need to select RGB1 and RGB2 colors.

Preset	Description	Preset	Description
0	No color effect	26	medium edge radial
1	Basic color override	27	soft edge radial
2	hard linear pre	28	thin horizontal bands
3	hard linear 90 degrees pre	29	medium horizontal bands
4	medium linear pre	30	thick horizontal bands
5	medium linear 90 degrees pre	31	unbalanced horizontal bands
6	soft linear pre	32	thin vertical bands
7	soft linear 90 degrees pre	33	medium vertical bands
8	hard linear post	34	thick vertical bands
9	hard linear 90 degrees post	35	unbalanced vertical bands
10	medium linear post	36	thin radial bands pre
11	medium linear 90 degrees post	37	medium radial bands pre
12	soft linear post	38	thick radial bands pre
13	soft linear 90 degrees post	39	thin radial bands post
14	angular pre	40	medium radial bands post
15	angular post	41	thick radial bands post
16	hard center radial pre	42	Single radial band pre
17	medium center radial pre	43	single radial band post
18	soft center radial pre	44	horizontal linear rainbow
19	hard center radial post	45	45 degree linear rainbow
20	medium center radial post	46	vertical linear rainbow
21	soft center radial post	47	angular rainbow
22	hard corner radial	48	center radial rainbow pre
23	medium corner radial	49	center radial rainbow post
24	soft corner radial	50	corner radial rainbow
25	hard edge radial	51	edge radial rainbow

Basic builder motion presets

For ease of operation there are many motion presets built for use with the basic builder modes. These motion effects all have a default size and speed, but you can override these defaults using the Motion Macro speed and size controls on channels 27 and 28.

Preset	Description	Preset	Description
0	No motion effect	31	Radial sine wave (before prism)
1	light sine wave (before prism)	32	radial ramp wave (before prism)
2	medium sine wave (before prism)	33	radial square wave (before prism)
3	dense sine wave (before prism)	34	Radial sine wave (after prism)
4	ultra light sine wave (after prism)	35	radial ramp wave (after prism)
5	light sine wave (after prism)	36	radial square wave (after prism)
6	medium sine wave (after prism)	37	radial morph 1
7	dense sine wave (after prism)	38	radial morph 2
8	light ramp wave (before prism)	39	radial morph 3
9	medium ramp wave (before prism)	40	radial morph 4
10	dense ramp wave (before prism)	41	radial morph 5
11	ultra light ramp wave (after prism)	42	radial morph 6
12	light ramp wave (after prism)	43	radial morph 7
13	medium ramp wave (after prism)	44	radial morph 8
14	dense ramp wave (after prism)	45	radial morph 9
15	light triangle wave (before prism)	46	radial morph 10
16	medium triangle wave (before prism)	47	party mode 1
17	dense triangle wave (before prism)	48	party mode 2
18	light triangle wave (after prism)	49	orbit
19	medium triangle wave (after prism)	50	orbit and rotate
20	dense triangle wave (after prism)	51	scroll left to right
21	moving wave 1	52	scroll right to left
22	moving wave 2	53	scroll 45
23	moving wave 3	54	scroll up
24	moving wave 4	55	scroll down
25	moving wave 5	56	ping pong vertical
26	moving wave 6	57	ping pong 45
27	moving wave 7	58	ping pong horizontal
28	moving wave 8	59	triangle orbit
29	moving wave 9	60	square orbit
30	moving wave 10		

ILDA Control

ILDA is an acronym for the International Laser Display Association and refers to both the organization and the analog control protocol standard for all laser projectors. Typically when you hear someone refer to ILDA control of a laser projector, they are talking about the control signal, not the organization.

The key difference between DMX and ILDA signals when it comes to controlling a laser projector such as the Skywriter HPX is that DMX is used to control gobos built into your projector electronics and ILDA is used to play content from your computer or other ILDA compatible playback device. With DMX you can take the gobos programmed into the laser projector and modify them using the other DMX channels to changes size, color, position, etc. With ILDA you get complete control over the content displayed, you can draw entirely new gobos or display custom text and graphics.

X-Laser recommends the use of Quickshow-XL or Beyond by Pangolin Systems for controlling your laser projector by ILDA. For comprehensive information on how to control your projector by ILDA please consult the video tutorials that come with your software package.

Please note that ILDA uses a DB-25 cable similar in appearance to those used by parallel port printers. Use of a standard 25 pin printer cable IS NOT RECOMMENDED as ILDA cables use a different pin out and have additional shielding to prevent interference.

There are two ways to activate ILDA input on your Skywriter HPX M-5 projector.

1. Using DMX or Art-Net with one Master fixture patched, change the Enable channel (channel 1) to “External Input”, or a value in the range of 4-7. This will route the External Input from your ILDA source through the projection area you have set using your Master zoning.
2. In the System Menu on the laser, set your control source to “Manual”. In your Manual Operation Menu, set your mode to “External input”. Your laser can now output from your ILDA source.

ILDA Settings

When using Quickshow or Beyond there are some specific settings to use for your Skywriter HPX. Go to the settings menu and select “Projector Settings”

1. Set your scan rate for 30000 and leave the other settings at their default.

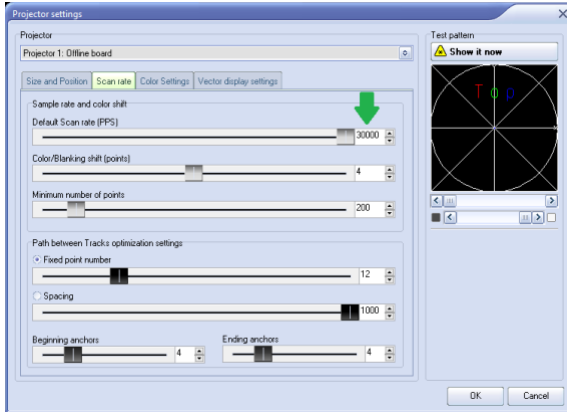

2. Set your color settings for 3 color RGB and Analog with log response.

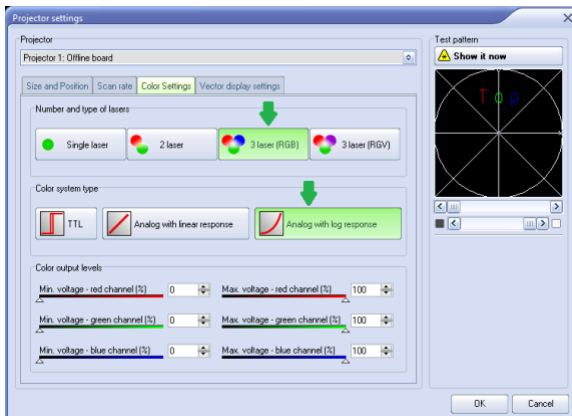

Troubleshooting

Here are a few simple solutions to common difficulties to try out first to get you up and running quickly. If you are having any difficulty with your laser projector, please feel free to contact us online, any time, at support@x-laser.com

<u>Problem</u>	<u>Solutions</u>
Unit does not power on	Check if power cable is secure in the wall outlet and unit power inlet.
	Verify that the power cable is functional by exchanging it with a new one, or testing the cable with another known-good device.
	Check if the power switch is turned on and illuminated.
Power switch is not illuminated	Check if the fuse is intact, if not replace with a new 5x20mm 250V 6.3A fast-acting fuse
	Verify the function of the AC circuit that powers the laser.
Replacement fuses continue to break	Contact X-Laser to return the unit for service.
No output. . .	
. . . in ILDA Mode	Check that the laser functions in DMX or Art-Net mode. If not, refer to the "No output in any mode" troubleshooting steps below.
	Verify that the ILDA cable is properly connected at both the laser and at the ILDA interface end.
	Verify that the ILDA cable is functional by exchanging it with a new one, or testing the cable with another known-good device.
	Carefully inspect the ILDA connectors on the laser and cables and verify that they are in good condition. If any of the 25 pins on the ILDA connector are broken on a cable, replace it with a new cable. If any pins are broken on your laser contact X-Laser for service.
	Verify that your ILDA interface and/or software is functioning properly--refer to the manufacturer(s) for proper troubleshooting steps.
	If using a Flashback 3 or 4 with Beyond or QuickShow XL, verify that the LED on the FB3/FB4 is rapidly flashing red. If not, check that the software has detected the FB3/FB4 and that your projection zones are routed to include the FB3/FB4 in question.
. . . in DMX mode	Verify that the system status screen shows that the unit is configured for DMX control, and the DMX status is "Ready".
	If DMX status indicates "Too Slow" . . .
	Check the refresh rate settings on your control system. By default, this system must receive a DMX packet at least once every 100ms to maintain output
	Check the DMX system for intermittent failures or marginal conditions that may be resulting in DMX packet loss.
	If DMX status indicates "Timeout!" . . .
	Verify that your DMX cabling is properly connected and that the DMX signal is propagating to the laser's position on the DMX chain. Use a dedicated DMX tester or other known-good DMX equipment to test.
	Connect the unit to your DMX controller directly via a single known-good DMX cable with no other DMX devices connected and check its function.
	Check the refresh rate settings on your control system. By default, this system must receive a DMX packet at least once every 100ms to maintain output
	Check the DMX system for intermittent failures or marginal conditions that may be resulting in DMX packet loss.
	If DMX status indicates "Ready" . . .
	Verify that the unit's DMX address matches the address set in your DMX controller. Try setting the unit to DMX address #1 and controlling it there to rule out DMX patching problems.

Problem	Solutions
	<p>Verify that the DMX profile you are using, if any, matches the projector's configured DMX profile. Try controlling the laser directly via channel values to rule out problems with your DMX profile. Refer to the user manual for the correct DMX parameters.</p> <p>Verify the function of your DMX controller with other known-good DMX equipment or with professional DMX testing tools.</p> <p>Verify that no geometric or color adjustments are being applied that would move output out of the projection field or make the intensity zero (For example, RGB values set to 0/0/0).</p> <p>Consult the user manual and Mercury Personality Guide and ensure that all required channels are set to proper values. Several channels must be non-zero to produce any visible output.</p> <p>Check that the laser functions in Manual mode (if possible). If not, refer to the "No output in any mode" troubleshooting steps below.</p> <p>Test the unit in other control modes, if applicable. If the problems persist in all modes or you are unable to test them, refer to the troubleshooting steps in the "in all modes" subsection below.</p> <p>Refer to the user manual's section on DIP switch/menu settings and verify that these are set correctly.</p>
. . . in Art-Net mode	<p>Verify that the system status screen shows that the unit is configured for Art-Net control, and the Art-Net status is "Ready".</p> <p>If Art-Net status indicates "Too Slow" . . .</p> <p>Check the refresh rate settings on your control system. By default, this system must receive an ArtDMX packet at least once every 2000ms to maintain output</p> <p>Check the Art-Net system for intermittent failures or marginal conditions that may be resulting in DMX packet loss.</p> <p>If Art-Net status indicates "Timeout!" . . .</p> <p>Verify that your Art-Net cabling is properly connected and that the network signal is propagating to the laser's position in the network. The Link/Act light on the etherStop port on the laser should illuminate green and flash amber on receiving any network traffic.</p> <p>If your controller supports Art-Net discovery, verify that the laser is detected. Otherwise, use an Art-Net discovery tool to verify that the laser is detected.</p> <p>Verify that the laser's IP address and subnet mask are correct for your control network.</p> <p>Verify that the laser's Art-Net universe is configured to match the controller's settings. The laser will only recognize ArtDMX packets directed to the universe for which it is configured.</p> <p>Verify that there is no network equipment (routers, filters, firewalls, etc) between the controller and the laser that may be blocking Art-Net signals.</p> <p>Check the refresh rate settings on your control system. By default, this system must receive an ArtDMX packet at least once every 100ms to maintain output</p> <p>Check the network system for intermittent failures or marginal conditions that may be resulting in ArtDMX packet loss.</p> <p>If Art-Net status indicates "Ready" . . .</p> <p>Refer to the section above for troubleshooting DMX mode. All of the DMX settings and troubleshooting steps apply to Art-Net as well.</p>
. . . in all modes	<p>Check that the system status screen shows that the Laser Status is "Enabled". If any others status is shown, refer to the manual on the Mercury system and the etherStop interface for guidance.</p> <p>Check that the remote interlock circuit or remote interlock plug, if applicable, are properly connected to the laser and enabled.</p>
DMX control is erratic or intermittent	<p>Verify that the DMX chain is properly wired. Generally DMX runs should:</p> <ul style="list-style-type: none"> - Use properly rated 120Ω shielded twisted-pair cable specified for DMX use - Be terminated after the last unit on the chain - Have no more than 32 devices on a single chain - Be absolutely no longer than 1000'/300m and preferably no longer than 300'/90m, total, from the DMX controller to the last device in the chain - Never be split or combined using passive adapters

Problem	Solutions
	- Use an active, isolated splitter to isolate different DMX segments when run over a large area, long distances, or a larger number of devices.
Art-Net control is erratic or intermittent	Verify that only one Art-net controller is transmitting ArtDMX packets to the laser's universe. Refer to the troubleshooting steps above for "No Output in Art-Net Mode"
Output is undersized, the wrong color, missing colors, or geometrically distorted . . .	
. . . in ILDA mode	Test the unit in DMX and AutoArt-Net modes, if applicable. If the problems persist in all modes or you are unable to test them, refer to the troubleshooting steps in the "in all modes" subsection below.
	Refer to the other ILDA troubleshooting steps above. Many of the problems that can prevent output entirely or cause erratic operation may also cause unexpectedly distorted output.
	Ensure that the projector scan rate in your ILDA control software is set properly for your laser. Refer to the user manual for proper scan rate settings. Unless otherwise noted, the maximum scan rate is specified at a projected full angle of 8°. Projecting at a larger angle will require a reduced scan rate to eliminate distortion. More importantly, <u>scanning at a wider angle without reducing the scan rate will damage the scanners.</u> Repairs to scanners that have been damaged by overdriving may not be covered under warranty.
	Test the unit in Art-net or DMX modes, if applicable. If the problems persist in all modes or you are unable to test them, refer to the troubleshooting steps in the "in all modes" subsection below.
. . . in DMX or Art-Net mode	Test the unit in other control modes, if applicable. If the problems persist in all modes or you are unable to test them, refer to the troubleshooting steps in the "in all modes" subsection below.
	Verify that no geometric or color adjustments are being applied that would move output out of the projection field or make the intensity zero (For example, RGB values set to 0/0/0) via DMX.
	Verify that the DMX profile in your control system is configured correctly and matches the DMX parameters of your laser.
	Consult the user manual and Mercury Personality Guide and ensure that all required channels are set to proper values.
	Refer to the "No output. . .in DMX mode" and "DMX control is erratic or intermittent" troubleshooting sections above. Many of the problems that can prevent output entirely or cause erratic operation may also cause unexpectedly distorted output.
	Test the unit in DMX and auto modes, if applicable. If the problems persist in all modes or you are unable to test them, refer to the troubleshooting steps in the "in all modes" subsection below.
	Power cycle the system, reset the system settings to defaults, and try again.
. . . in all modes	Verify that size/color adjustments at the laser itself, if applicable, are set correctly.
Laser makes a rattling or "growling" sound that persists even when not outputting.	This is usually a sign of a failing cooling fan. If the sound does not stop within one minute of power on contact X-Laser to return the unit for service.

<u>Problem</u>	<u>Solutions</u>
<p>Output of laser projector is heavily distorted and the laser makes a high pitched "squealing" noise when scanning</p>	<p><u>TURN OFF THE LASER IMMEDIATELY.</u> These are symptoms of a serious problem with the laser's scanning hardware and continuing to operate the laser for even a few minutes may cause permanent damage. If using ILDA mode, refer to the ILDA mode troubleshooting sections and carefully check your ILDA software settings and cables in particular before attempting to power the laser back on. If these problems occur in DMX or auto modes, or continue to occur in ILDA mode, contact X-Laser to return the unit for service.</p> <p>Note that a faint high pitched whine is not unusual with complex content and is not a cause for concern as long as the output is not distorted. This caution does not apply to stepper-based laser projectors which make more noise in normal operation and are not susceptible to catastrophic failure.</p>

Repair and Return Information

Product Registration

Register Your Product: You must first register your X-Laser product at www.x-laser.net/warranty.fwx to activate your warranty. Failure to do so may result in loss of warranty service. ALWAYS KEEP YOUR PRODUCT BOX FOR SAFE RETURN PACKAGING.

Return Material Authorization (RMA) and Shipping

PLEASE NOTE: All returns will incur a \$50 bench fee which will be waived if a) the product is repaired under warranty, b) the client elects to repair an out of warranty unit, or c) the unit is beyond repair and is disposed of with the client's authorization. The bench fee covers an initial evaluation, basic internal cleaning and basic alignment and calibration.

Please first contact X-Laser for an RMA number. Our support team will most likely spend a few minutes trying to diagnose the issue over the phone to find the fastest resolution for you. If the laser needs to be returned, you will be given an RMA number and a URL to complete the RMA process. All information you will need to return your laser is noted on the RMA web site. Upon completion of the online RMA form, a PDF with shipping instructions will appear.

Return shipping instructions will be located on the PDF form that pops up after you have completed and submitted the online RMA form. Follow shipping, packaging, and insurance instructions. X-Laser is not responsible for any shipping damages by shipper and/or poor client packaging.

Shipping within Continental USA

X-Laser pays return FedEx ground shipping to the customer for warranty and DOA repairs only. Out of warranty work shipping is paid by user in both directions. Faster shipping will incur an extra shipping fee.

Shipping outside Continental USA

X-Laser pays for FedEx return ground shipping to the customer or freight forwarder within continental USA for warranty or DOA repairs only. Out of warranty work shipping is paid by user in both directions. Shipping costs for parts, if approved by X-Laser, are paid by client. Faster shipping will incur an extra shipping fee.

Out of Warranty Repairs

X-Laser will evaluate the product and contact the user for repair authorization. Payment must be remitted by credit card or PayPal prior to service. Costs for repair are based on product model. Products not authorized for repair will be returned at user's expense. Following first request for repair authorization, a storage fee per month will be assessed. After sixty days product will be considered abandoned and disassembled.

General Notification

X-Laser at X-Laser's sole discretion reserves the right to:

- Change this policy without prior notification;
- Determine what is to be repaired and or replaced;
- Determine warranty status or repair and evaluation charges;

- Determine if a product has been misused, tampered, or damaged resulting in repair charges;
- Determine if user is to pay for return shipping;
- Determine charges for general maintenance and laser realignment.

Manufacturer's Limited Warranty

X-Laser warrants that this product will be free from defects of materials or workmanship for 12 months for the mechanical components of the laser system and 6 months for the laser diodes from the date of end-user purchase. This warranty will only apply to laser systems purchased from an authorized X-Laser dealer. This limited, non-transferable, warranty does not cover product abuse, exposure to the elements, accidental damage, shipping damage, improper usage, liquid or smoke damage (including fog juice), or units which have a broken factory seal, have been modified, rented, transferred to a third party, or are more than 12 months old.

Limitation of Liability

By using this product, the end user certifies that he/she is familiar with and agrees to practice all industry standard laser safety procedures and all such procedures contained herein. The purchaser of this product acknowledges that they have been advised that an FDA variance is required prior to use of any Class 3B or 4 laser system and the purchaser certifies that this product will only be operated by employees of the variance holder and in accordance with the terms of the variance. X-Laser specifically disclaims any liability arising from improper or unsafe usage of this product, usage without an active variance, or usage of this product in any manner other than intended. By using this product, the end user agrees to indemnify and hold harmless X-Laser LLC, its dealers and distributors, employees and staff, subsidiaries, and partners in any action arising from use of this product. Finally, the end user also agrees that prior to any use of this product, he/she shall have in effect a liability insurance policy with a sufficient per incident limit to cover any claims arising from the use of this product. Any purchaser who does not agree to these terms may return their unused X-Laser product within 7 days of purchase for a full and unconditional refund.

Return Policy

We want you to love using your X-Laser. If you don't love it, for whatever reason, please contact us so that we may help resolve whatever the issue may be. Factory sealed products may be returned to your dealer in accordance with their return policies. Used products may be returned for any reason within 14 days of purchase, assuming that they are in excellent condition, with a restocking fee of 15%. This fee is high in comparison to some other devices primarily because each returned unit has to be fully reconditioned and certified to be in compliance with FDA regulations before it can be resold to another client. This process is time consuming and costly, especially for just one unit at a time, and thus the restocking fee is required.

Sample Laser Operator Show Checklist

It is highly recommended that laser operators use a per show checklist to ensure their system is set up safely and in accordance with any federal or local regulations. This sample checklist can be used or modified as needed. Some blank rows have been added for your convenience. This checklist was

designed for US compliance, for other countries please consult local laws. For a copy of the template so you can place your own logo, please contact support@x-laser.com.

Laser Operator Show Checklist

Operator Name: _____ Show/Venue name: _____

Show date:							
Laser projectors securely mounted							
Lasers properly connected to control							
Safe projection zone set in control							
Physical beam blocks securely attached							
All beams terminate safely							
All beams maintain required safety clearances							
Laser projectors respond to control inputs correctly							
Operator has clear view of all beam paths and termination points							
Operator is trained and holds a current variance or is employed by a variance holder							
Copy of active variance on site							
All laser emissions can be terminated by at least 2 methods							
Laser warning sign(s) posted if required							

Sample Laser Signage

Signage is not typically required, but is never a bad idea. Here's a sample laser notification sign you can use, just fill out the power level of your laser. Be aware that this is not accurate for audience scanning shows. For a copy of the template to put your own logo on, contact support@x-laser.com.

**THIS SHOW
USES LASERS!**

Don't worry, these lasers are safe and compliant with 21CFR1040.10 and IEC 60825-1 and are being controlled by a trained and varianced laser operator.

The lasers used in today's show are Class 4, < ___ watts and use DPSS and/or direct injection diode lasers in the range of 405-660nm. Report any beam access to the laser operator.

ENJOY THE SHOW!

X-LASER

Document History

2018-04-30	Initial Release
2018-08-21	Updated to reflect SW v0.1.17
2018-09-14	Corrected Master profile position channel data
2020-08-05	Corrected DMX values in wave section and master section
2020-08-06	TOC update and XLERATE sections added

Questions? Feedback?

If you have any questions about any of the content of this manual or the safe operation of your new laser projector or would like to give us some feedback on our products or documentation, please do not hesitate to contact your dealer or X-Laser directly.



301-543-1981

866-702-7768

Sales – Dial 1

Support – Dial 2

General Information – Dial 0

support@x-laser.com

www.x-laser.com

info@x-laser.com

9125A Whiskey Bottom Road, Laurel, MD 20723 USA